



96890-084 Safety Beam System

Installation Instructions

GENERAL

The 96890-900 Safety Beam System responds to the evolution of requirements in the area of safety for pedestrian automatic doors. Thanks to their reduced size, they integrate discretely in any door frame. The increase in micro-processed door operators, the setting of new safety standards, and the concern for better protection of pedestrians have driven the development of a more flexible, more effective new line of beams.

TECHNICAL SPECIFICATIONS

Technology	Microprocessed active infrared
Mounting Height	Minimum 1' above floor
Distance between pairs of beams	Minimum 1' (note: beams must be crossed)
Distance between heads and the plane of the doors	1"
Range of detection	Minimum 3' - Maximum 15'
Alignment tolerance	8°
Detection method	Presence (by beam interruption)
Response time	≤ 40 ms
Hold time	300 ms
Power supply	12 - 24 V AC ± 10% 12 - 24 V DC -5% / +30%
Consumption	< 100 mA
Output contact rating	1 relay (NC/NO contacts)
<ul style="list-style-type: none"> • Max. contact voltage • Max. contact current • Max. switching power 	50 V DC / 50 V AC 1 A (resistive) 30 W (DC) / 60 VA (AC)
Displays	2 red LEDs, lights when barrier is interrupted
Adjustments	Dip switches
Operating temperature	-30° to +131° F
Immunity	
<ul style="list-style-type: none"> • Ambient light • Incandescent light • Electromagnetic compatibility 	75000 Lux 25000 Lux with an angle of 8° in accordance with 89/336/EEC (CE)
Protection	Nema 4 Enclosure (IP 65)
Dimensions	
<ul style="list-style-type: none"> • Heads • Control Board 	body: $15/32''$ (L embed) x $15/32''</math> Øharness: Ø 5/8''</math>3'' (w) x 2'' (d) x 1.1'' (h)$
Cable length	15' or 30' (specify when ordering)
Weight	
<ul style="list-style-type: none"> • Emitter head (with cable) • Receiver head (with cable) • Control Board 	4.8 oz. 4.8 oz. 2.0 oz.
Material	ABS
Housing color	Transparent
Cable color	
<ul style="list-style-type: none"> • Emitter head • Receiver head 	Grey Black

WIRING DIAGRAM

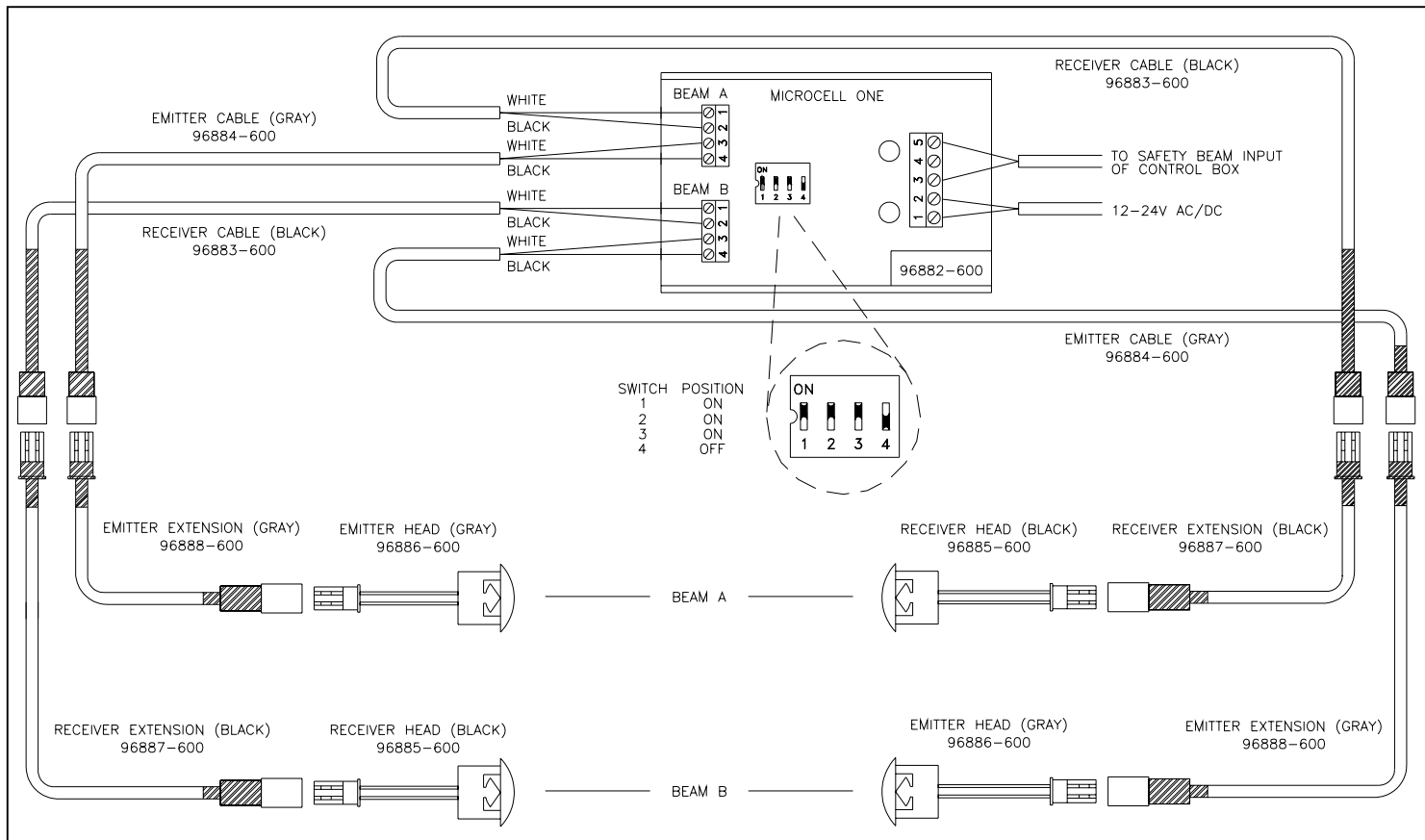

SETTINGS & CONNECTIONS

The safety beam control box should come from the factory pre-set for the application, but it is a good idea to verify the settings and/or make any necessary adjustments.

1. Snap off the top of the safety beam control box.
2. Set the desired operation of the safety beam system with the switches.

Switch	ON	OFF
1	Double beams	Single beam
2	Active (normally open contact-connect to NC & COM)	Passive (normally open contact-connect to NO & COM)
3	Standard operating range (15')	Reduced operating range (10')
4	Test	Default

3. Connect the safety beam harnesses to the terminal blocks as shown above. NOTE: When using a single set of beams, connect to the "Beam A" terminal block and set Switch 1 to the OFF position.
4. Connect 12-24V AC/DC supply to the terminal block (1 & 2) as shown above.
5. Connect the COM & NC terminals (3 & 5) to the door control as shown above.
6. Replace control box cover.