

# DOR-O-MATIC 96K-SLIDING DOOR INSTALLATION TIPS

## ATTENTION – READ THIS FIRST!

This document is designed to help with the installation of the Dor-O-Matic 96K Sliding Door System. While there are some similarities to the Astro-Slide System, there are many more differences. Please read these recommendations, along with the Installation Instructions (P/N 96000-984) provided on the parts board, before installing the 96K System.

### Wire Cover

- Cut the wire cover into several pieces 6" to 10" long, and install as needed (Figure 1).

### Sensor Wiring

- Install a length of 6-conductor cable from the control box to the center of the door opening and a length of 2-conductor cable from the transformer box to the center of the door opening in the front wire channel with the pieces of plastic wire cover (Figure 1). These cables are for the motion detectors (P/N 74600-900)

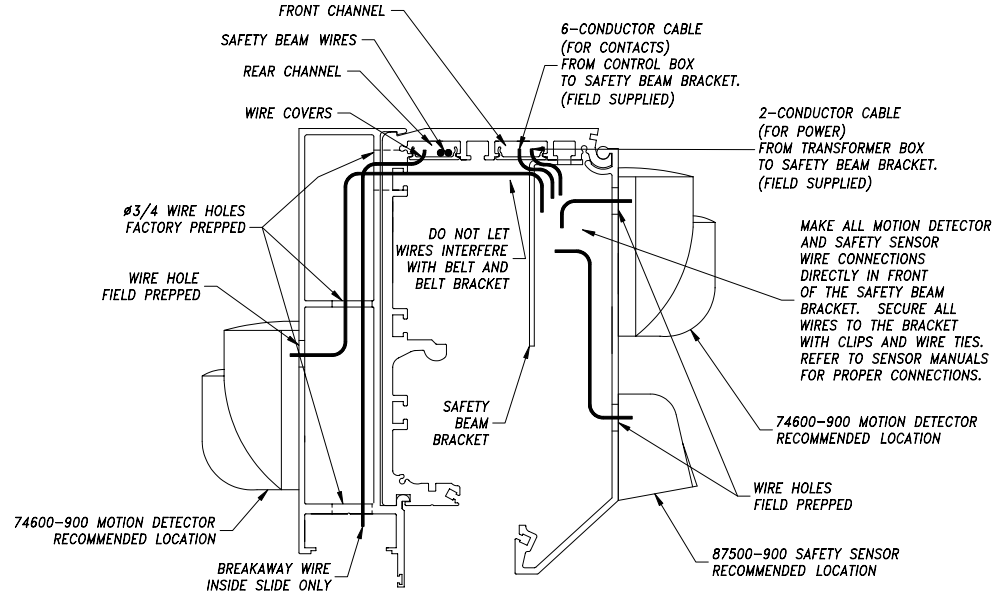

**FIGURE 1: Header Cross Section**

- Install the motion detectors and safety sensor at the recommended height locations in the center of the door opening (Figure 1). Note the factory prepped wire chase holes in the header and header extension (Figure 1).
- Slide the safety beam bracket to the center of the door opening. Make all wire connections for the sensor and motion detectors in front of and secured to the safety beam bracket (Figure 1). Refer to the individual sensor manuals and the 96K Control Box Manual (P/N 96010-084) for the proper wiring connections.

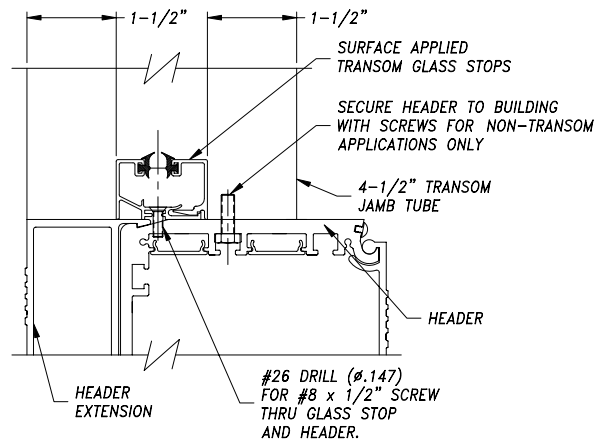

**FIGURE 2: Transom Cross Section**

### Non-Transom Applications

- Use three 1/4-20 screws per jamb. Install additional screws up through the header into the building (Figure 2).

### Transom Applications

- Use three 1/4-20 screws per jamb. Center the transom glass stops in the jamb tubes (Figure 2). Drill #26 (.147 dia.) holes through the exterior glass stop and header and install the #8 x 1/2" screws provided.

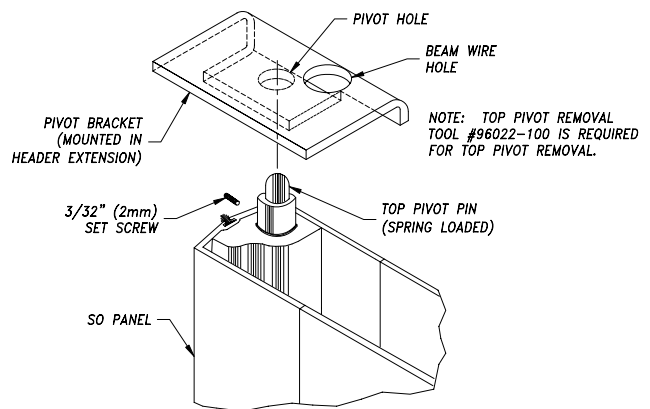

**FIGURE 3: SO Pivot Detail**

### SO Panel

- When installing the SO panel (inside slide only), be sure to release the top pivot pin into the hole (Figure 3). Take care not to pinch or cut the safety beam wires during installation. Route the safety beam wires in the rear channel.