



---

# Series 96000 Sliding Door

## Installation Instructions

### **DOR-O-MATIC®**

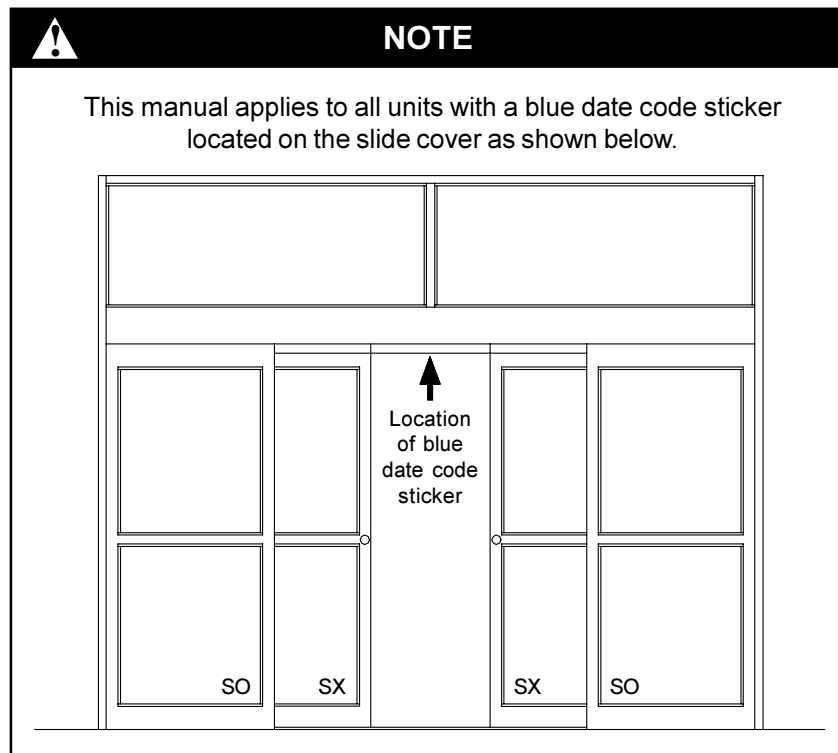
7350 W. Wilson Ave.  
Harwood Heights, IL 60706

Toll Free: 1-800-543-4635  
In Illinois: 708-867-7400  
Sales FAX: 708-867-0291  
Technical Support: 1-888-942-9945  
[www.doromatic.com](http://www.doromatic.com)

Copyright © 2003 Ingersoll-Rand.  
All rights reserved.

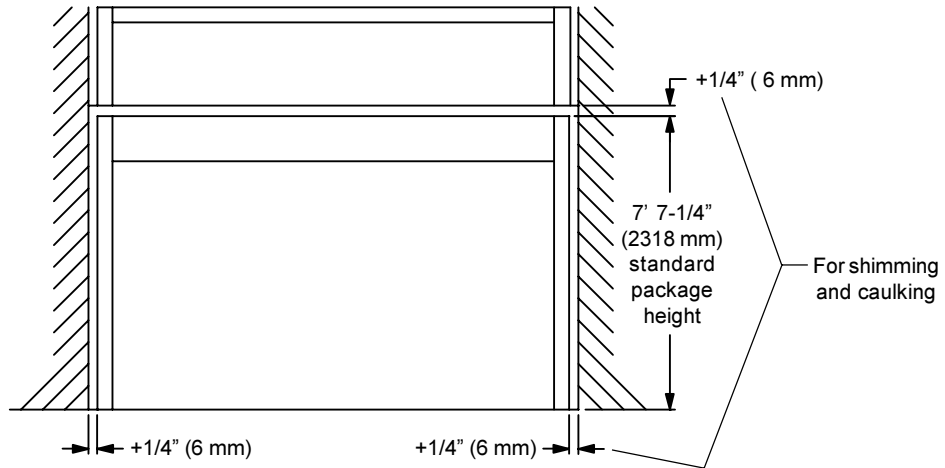
## INDEX

Inspection .....	3
Header and Jamb Mounting .....	4
Threshold Installation – Full Breakout Application .....	6
Threshold Installation – Fixed Panel Application .....	7
Package Components .....	8
Panel Installation – Full Breakout Application .....	9
Panel Installation – Fixed Panel Application .....	10
Door (SX) Installation .....	11
Limit Arm and Bumper Bar Installation .....	14
Wiring Diagram .....	15
Glazing .....	15
Release for Service .....	16



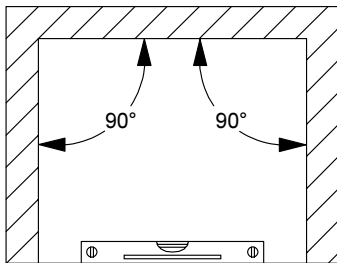
## INSPECTION

1. Verify that the shipped order is complete and correct. Check model number, color, and package width and height.
2. Verify at the **job site** that **all conditions** are correct and in accordance with **final approved shop drawings**.
  - 2.1. Check that the opening is the correct size. Correct size is package width plus 1/2" (13 mm) and package height plus 1/4" (6 mm) for shimming and caulking (**Figure 1**).

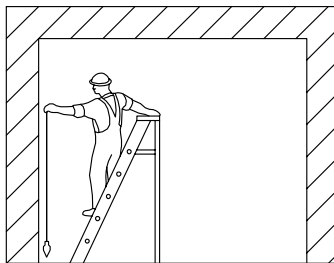


**Figure 1.** Clearance Required at Rough Opening

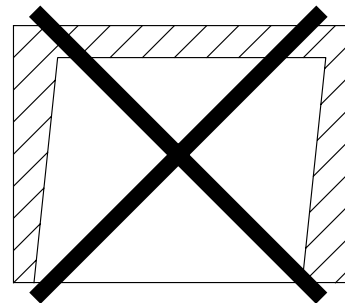
- 2.2. Check that the floor is level. Use a level of 6' 0" (1829 mm) minimum length (**Figure 2**).
- 2.3. Use a plumb bob to check that the rough opening where the jambs will be mounted is vertical (**Figure 3**).
- 2.4. Check diagonal measurements to insure that opening is a true rectangle, not just a parallelogram (**Figure 4**).



**Figure 2.** Floor Must Be Level



**Figure 3.** Jamb Mounting Surface Must Be Vertical



**Figure 4.** Opening Must Be Rectangular, Not a Parallelogram

- 2.5. Check that the electrical feed (115 V, 15 A single phase for North America, 220/240 V, 5 A single phase for Europe, Asia, etc.), conduits, and electrical junction boxes for push plates or other activation devices (if required) are correctly located in accordance with final approved shop drawings.

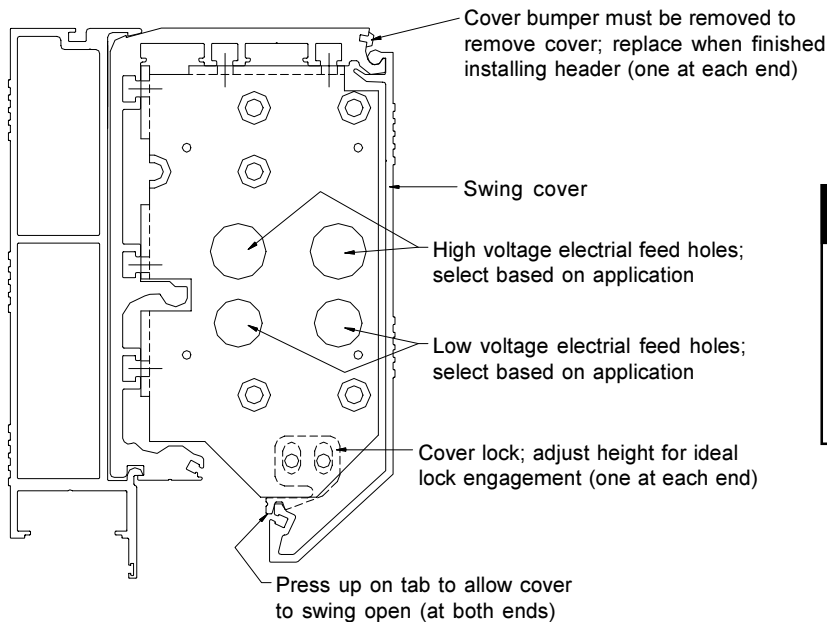


### NOTE

If any of the above items are not correct, **do not attempt to install the Series 96000 Slide package!** Report any incorrect items to the general contractor **immediately**. Do not proceed until all conditions are correct.

## HEADER AND JAMB MOUNTING

1. Open the carton marked "HEADER." Remove the header and set it on a piece of cardboard with the swing cover facing up. Remove the cover bumpers near the cover hinge. Do not lose the cover bumpers, as they must be re-installed to prevent the cover from coming off when opened. Using a screwdriver, press up on the cover lock tab (one on each end) to disengage and open the cover (**Figure 5**).

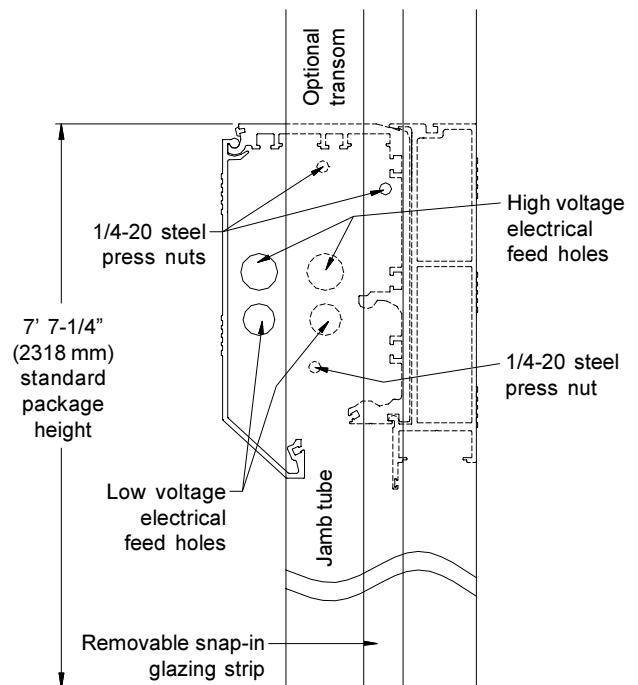


**NOTE**

High voltage (incoming 115 VAC) wires and low voltage wires cannot share the same access hole. High voltage wires must be routed away from all low voltage wires. Use wire clips supplied on parts board.

**Figure 5. Cover Removal**

2. Within the header (factory installed) are the motor/gearbox with drive pulley, drive belt, idler pulley and tensioner assembly, control box, transformer box, holding beam control box, any switches, and the terminal block bracket. Additional items are shipped in a blister pack, and these should be laid out in a convenient location.
3. Align the jamb tubes with the ends of the header, making sure that the bolt holes and electrical feed holes line up. Use three 1/4-20 x 1" long bolts on each side to secure the header end cap to each jamb tube. Then install one dress end cap on each side using the #8-32 screws (**Figure 6**).



**Figure 6. Jamb Tube Attachment to Header**

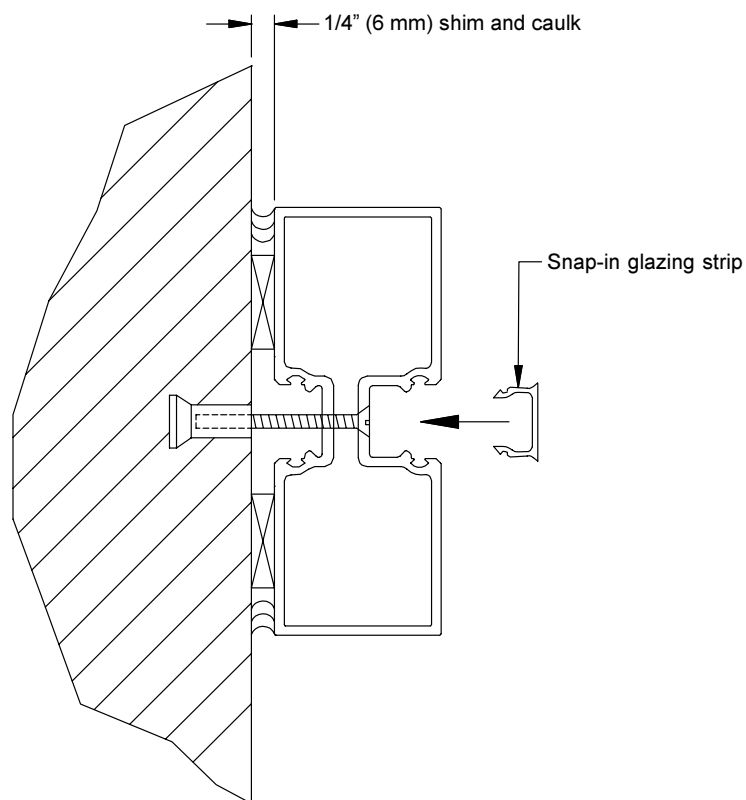
## HEADER AND JAMB MOUNTING (continued)

4. For each jamb, insert wood tapered shims to plumb each jamb. Insert 1/4" (6 mm) spacers around the header or horizontal transom tube at anchor locations to keep the tubes from being pulled tight.
5. With a helper, tip up the jamb/header assembly and position it within the rough opening, making sure the swing cover is on the correct side. Verify that the package is located correctly within the rough opening (refer to the final approved shop drawings). The Series 96000 Slide package is **usually** centered within the opening or is mounted flush with the curtain wall, but verify the position with the drawings, contractor, architect, etc.
6. Use appropriate fasteners (four per jamb) to anchor through the glazing recess of the jamb tube to the wall or adjacent framing. Check the jamb tubes with a level to be sure that the tubes have not been pulled in by the anchors. Finally, install the snap-in glazing strips in the jamb tubes (**Figure 7**).
7. The standard package height is 7' 7-1/4" (2318 mm). On occasion, the approved shop drawings require a package height of 7' 6-3/4" (2305 mm). If this is the case, cut off 1/2" (13 mm) from the bottom of each jamb tube in the field. This generally is performed for a recessed threshold application.



### NOTE

If the package being installed is over 10' 0" (3048 mm) wide and has a transom, a vertical transom tube must be anchored securely to the top transom tube in order to prevent deflection in the header.



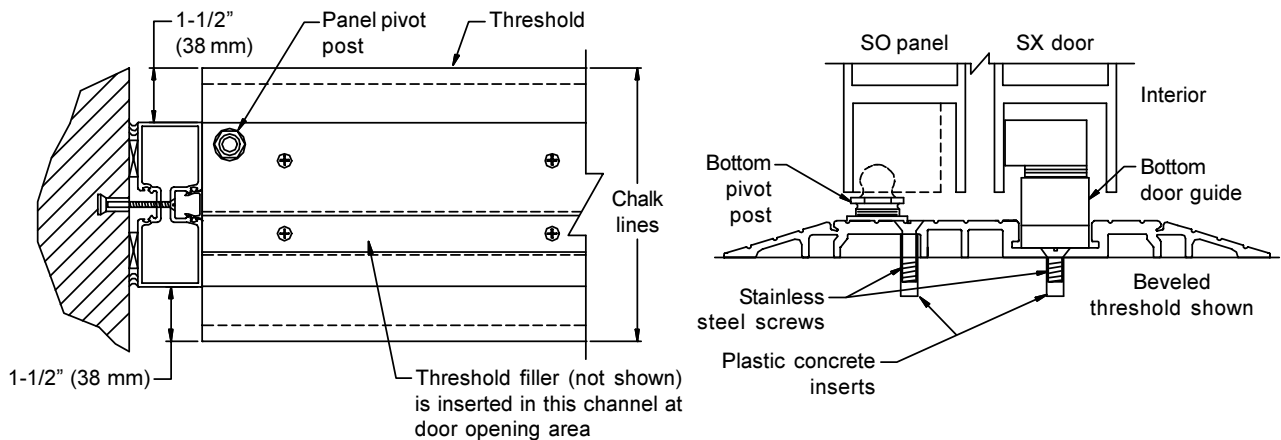
**Figure 7.** Anchoring the Jamb Tube

## THRESHOLD INSTALLATION – FULL BREAKOUT APPLICATION

1. After verifying that the floor is level, snap a chalk line 1-1/2" from the face of each jamb on both sides. Place the threshold between the jamb tubes within the chalk lines.
2. Verify that the panel pivot in the threshold is on the EXTERIOR side of the opening. Keep the threshold within the chalk lines, and use it as a guide to drill through holes into the floor. Place plastic concrete inserts into the drilled holes. Use the stainless steel screws from the blister pack to fasten the threshold to the floor (**Figure 8 and Figure 9**).

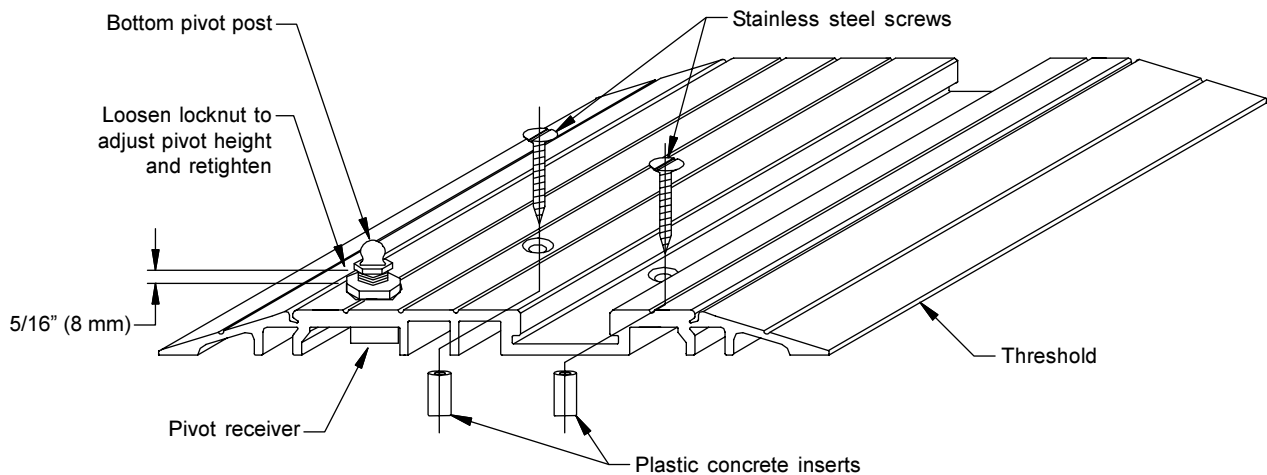
**NOTE**

A different extrusion is provided for a Full Breakout Package with a recessed threshold option.



**Figure 8.** Installation of Threshold

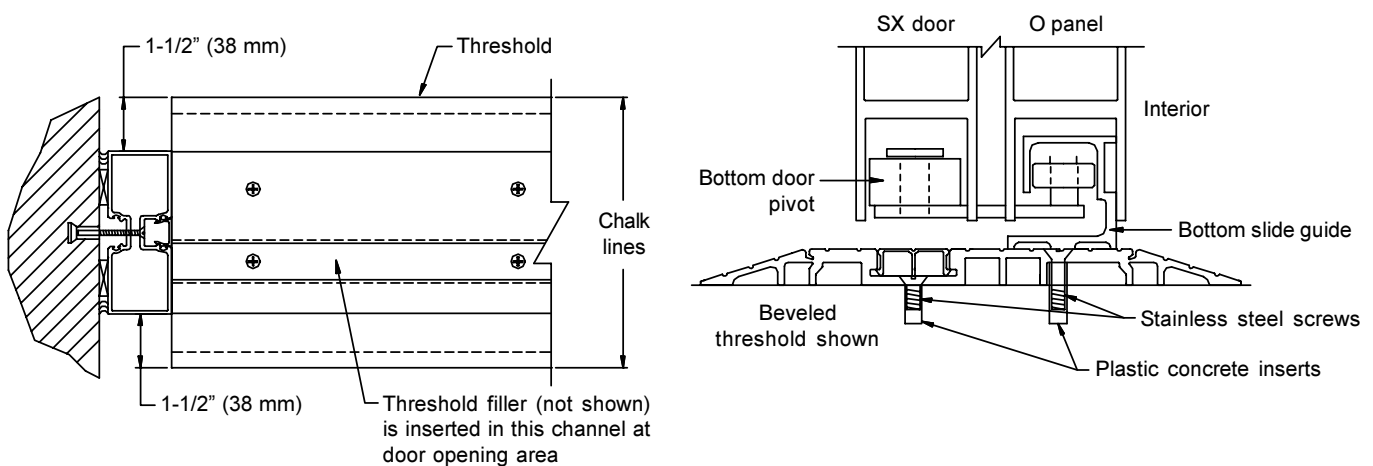
3. Thread bottom pivot post (from blister pack) into pivot receiver in threshold and adjust to correct height (**Figure 9**). Install the threshold filler at the door opening area with a rubber mallet.



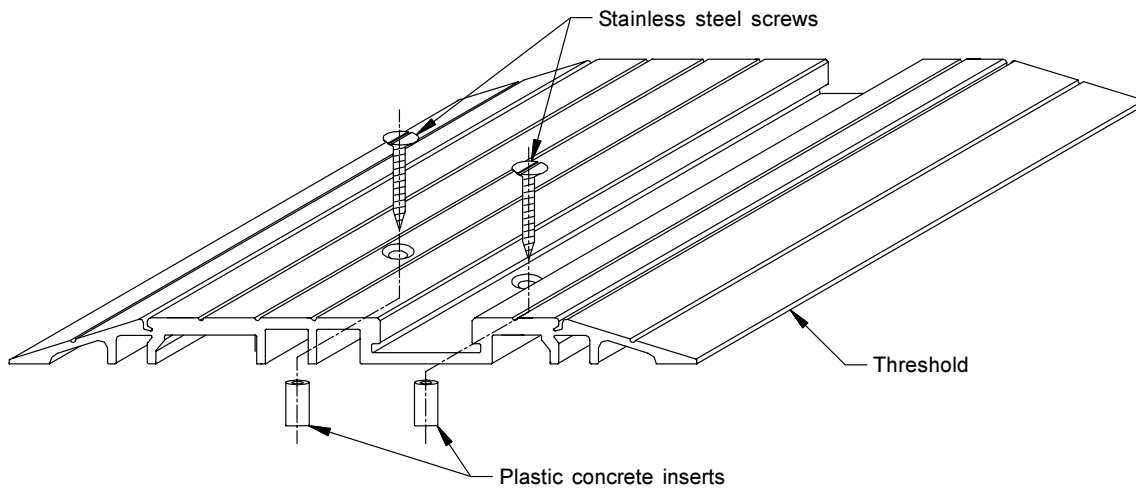
**Figure 9.** Bottom Pivot Post Attachment

## THRESHOLD INSTALLATION – FIXED PANEL APPLICATION

1. After verifying that the floor is level, snap a chalk line 1-1/2" from the face of each jamb on both sides. Place the threshold between the jamb tubes within the chalk lines (**Figure 10**).
2. Verify that the track portion in the threshold (where the filler is to be located) is on the EXTERIOR side of the opening. Keep the threshold within the chalk lines and use it as a guide to drill through holes into the floor. Place plastic concrete inserts into the drilled holes. Use the stainless steel screws from the blister pack to fasten the threshold to the floor (**Figure 10 and Figure 11**).
3. Install the threshold filler at the door opening area with a rubber mallet.



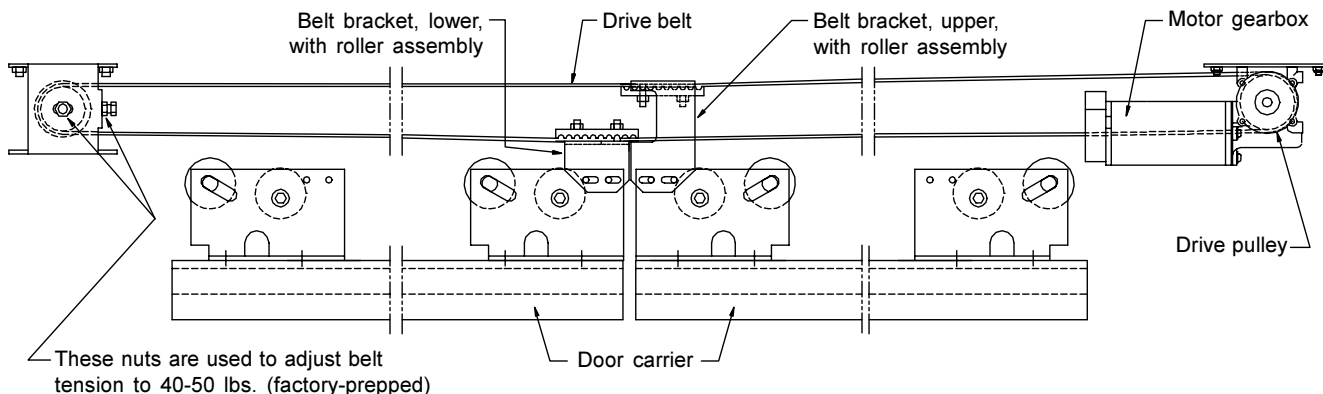
**Figure 10.** Installation of Threshold



**Figure 11.** Isometric of Threshold

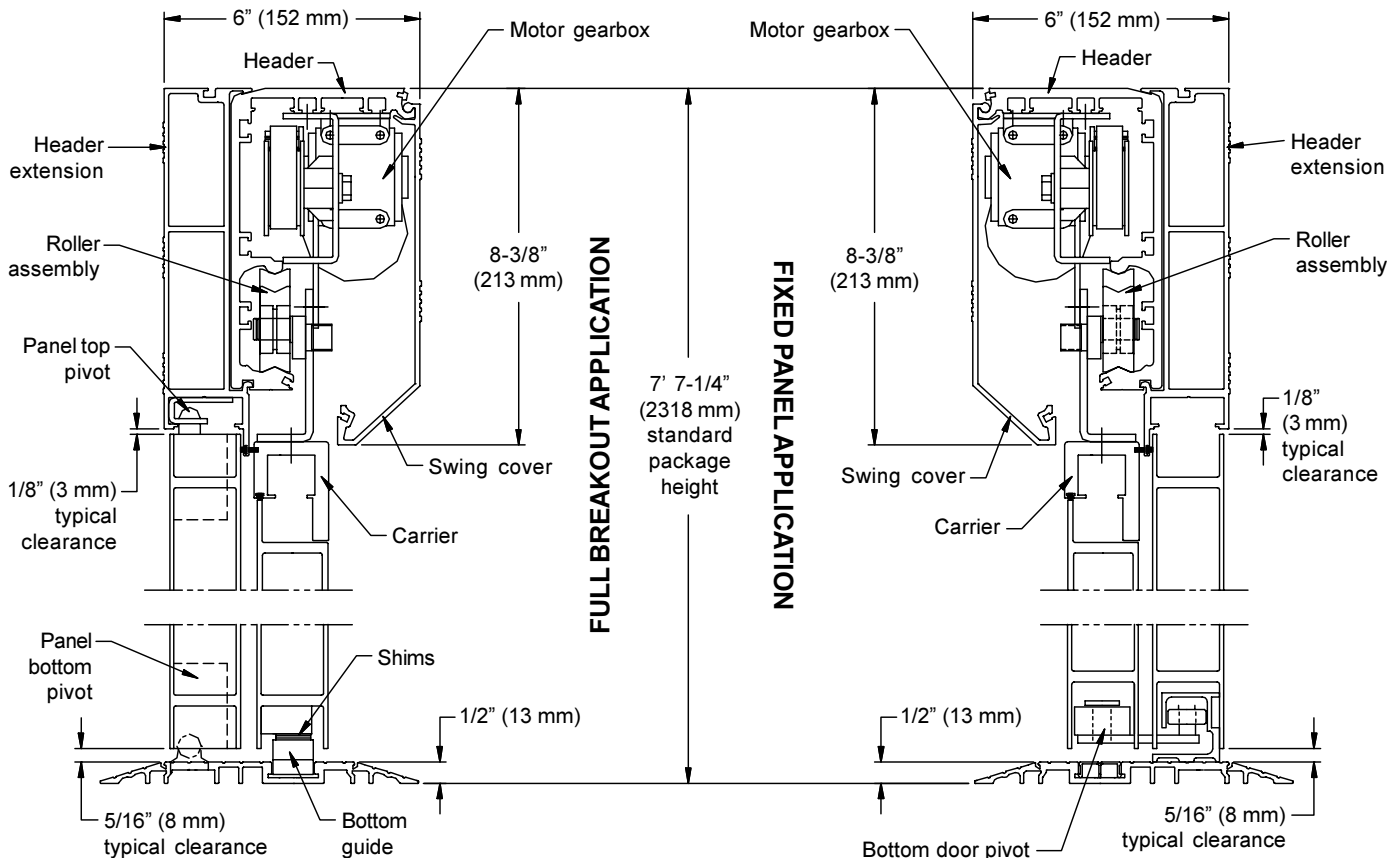
# PACKAGE COMPONENTS

1. Refer to **Figure 12** for a detailed breakdown of internal drive components.



**Figure 12. Belt Drive Assembly**

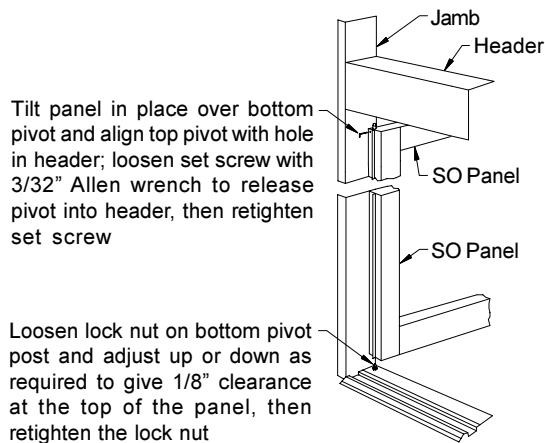
2. Refer to **Figure 13** for a detailed section view of a typical Series 96000 Slide Full Breakout or Fixed Panel application.



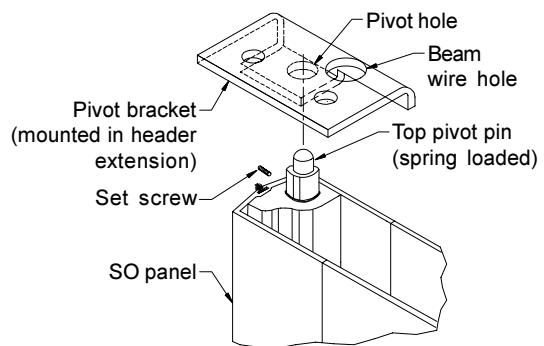
**Figure 13. Section View through Header, Door, and Panel**

## PANEL INSTALLATION – FULL BREAKOUT APPLICATION

1. Remove panels from carton. Lift panel and place bottom pivot block (factory-prepped and installed in bottom panel stile) onto bottom pivot post. Check clearance at top of panel for 1/8" gap.
2. If necessary, remove panel and adjust bottom pivot post to give the required 1/8" clearance at the top of the panel (**Figure 14**).
3. Top pivot pin is shipped in retracted position. Loosen set screw and release top pivot pin into the hole in the bracket (**Figure 15**). Tighten set screw when top pivot pin is set.
4. If necessary, use top pivot removal tool #96022-100 to remove panel. Loosen set screw and push pin down with the tool (**Figure 16**).



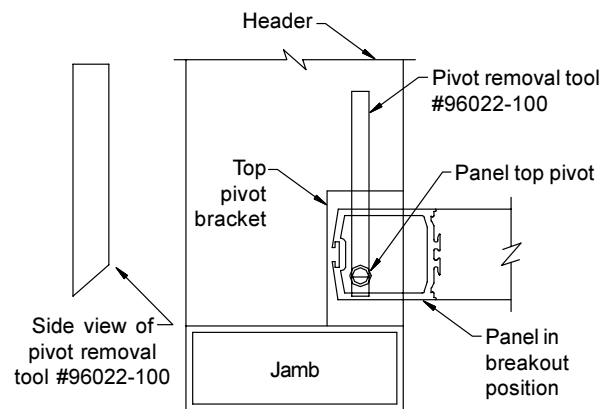
**Figure 14.** Panel Installation Detail



**NOTE**

Top pivot removal tool #96022-100 is required for top pivot removal

**Figure 15.** Panel Top Pivot Detail



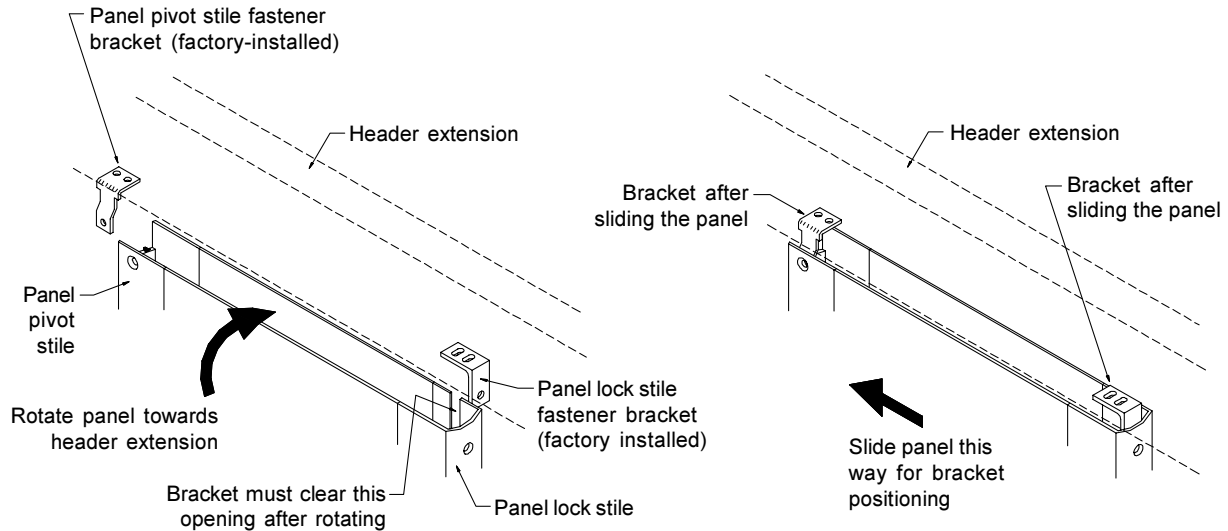
**NOTE**

Be careful not to damage or cut the pencil beam cables that run through the top pivot bracket when removing the panel

**Figure 16.** Panel Removal Detail

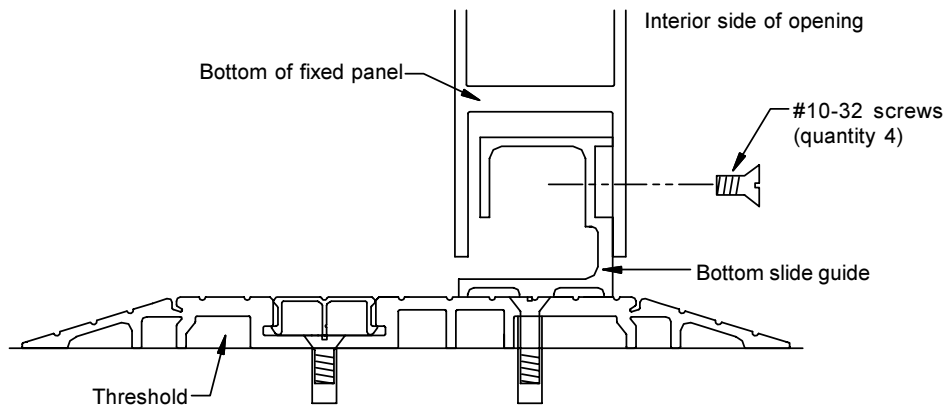
## PANEL INSTALLATION – FIXED PANEL APPLICATION

1. Remove the slide guide from its packaging. Use the factory-prepped holes on the slide guide as a template to drill the same number of holes into the threshold.
2. Remove the fixed panel from its carton. Lift panel and place bottom rail (factory-prepped stile and rail) onto bottom slide guide with four (4) drilled holes at bottom of panel facing interior side of opening. Swing upright, clearing the lock stile fastener bracket with the slot machined in the lock stile of the panel (**Figure 17**). Slide panel towards jamb tube and install 1/4-20 flat head screws from screw bag.



**Figure 17.** Panel Positioning and Attachment

3. Once the top of the panel is properly fastened, install the #10-32 screws into the holes at the bottom on the interior side of the opening to attach the panel to the slide guide (**Figure 18**).



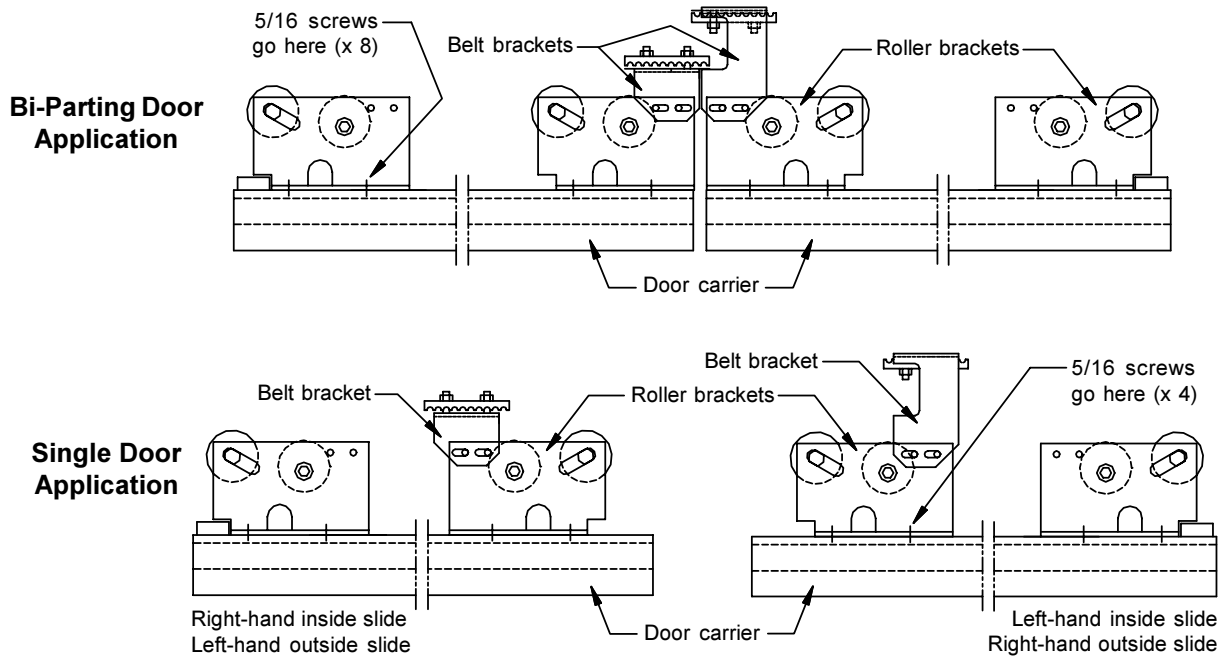
**Figure 18.** Bottom of Panel Installation

# DOOR (SX) INSTALLATION

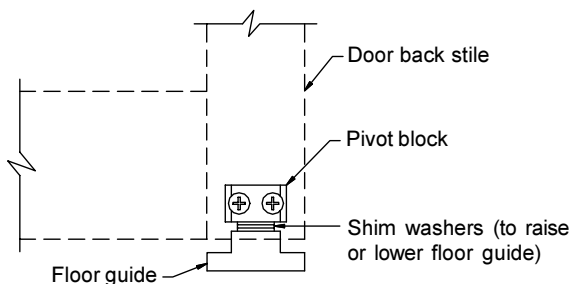


## IMPORTANT

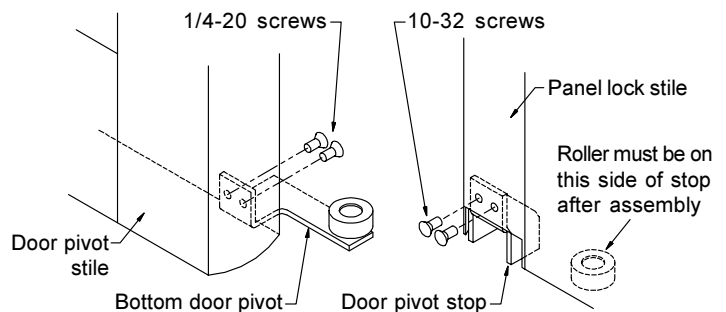
Carefully refer to the following diagram for proper locations of the belt and roller brackets when installing the door portion of your application.



1. Remove the doors from the carton. All mention of M6 nuts and bolts refers to the thread diameter. Use a 10 mm socket or 10 mm open-end wrench when removing or installing these fasteners.
2. Attach the roller assembly to the door carrier using the 5/16-18 x 5/8" socket head screws and lock washers supplied. (Bi-Parting unit has two doors.)
3. Remove the sliding door bottom pivot assembly (which includes the floor guide) from the blister pack. Install the bottom pivot assembly into the bottom of the vertical door stile through the two prepped and countersunk holes with the 1/4-20 x 3/8" long flat head screws provided (**Figure 19**). (**Note:** Full breakout and fixed panel packages have different door bottom pivot components.)



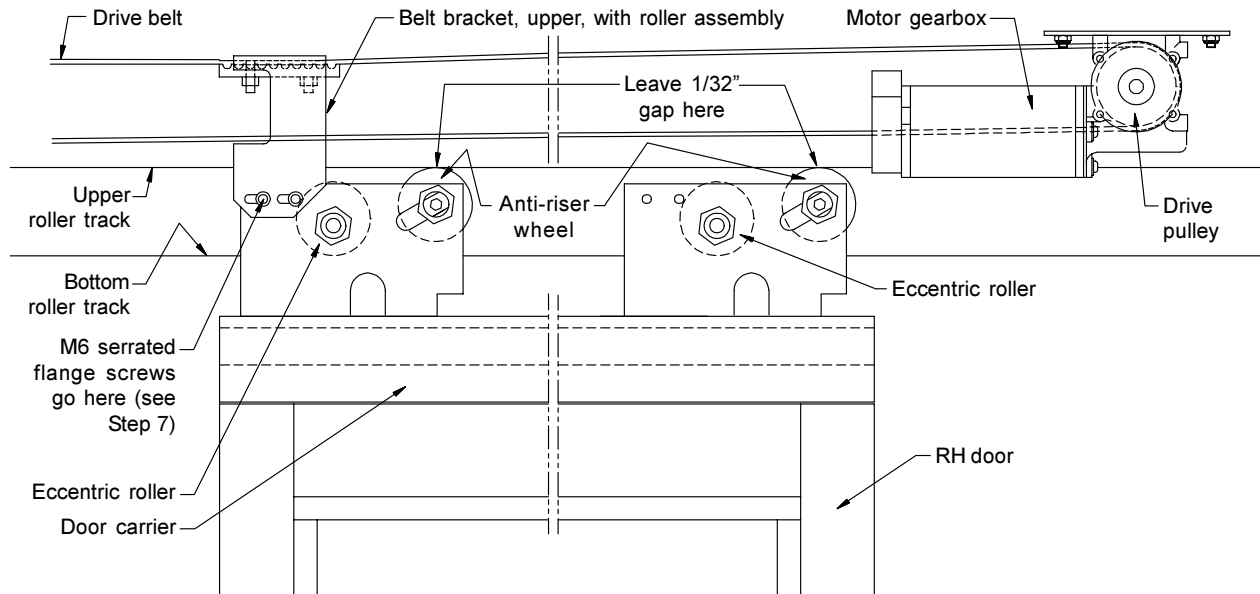
**Figure 19a.** Installation of Door (SX) Bottom Pivot Assembly for **Full Breakout Application**



**Figure 19b.** Installation of Door (SX) Bottom Pivot Assembly for **Fixed Panel Application**

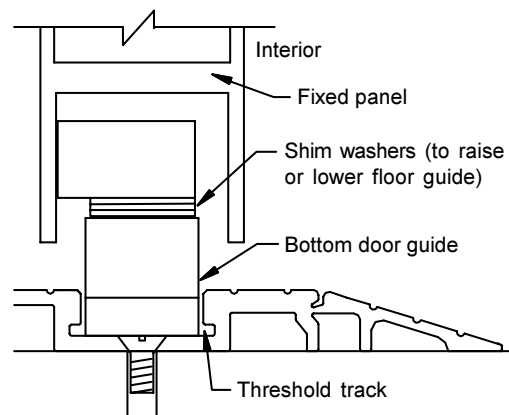
## DOOR (SX) INSTALLATION (continued)

4. Use a 15/16" wrench to loosen the anti-riser wheel, then place it in the down position to allow access into the roller track. Hang the door, ensuring that the eccentric wheel contacts the bottom roller track surface (**Figure 20**).



**Figure 20.** Anti-Riser Adjustment and Door (SX) Attachment Procedure

5. **FOR FULL BREAKOUT APPLICATIONS:** Verify that the bottom guide is in the threshold track and slowly slide the door back and forth to assure smooth operation. Check to see if the floor guide is deep enough in the track. It may be necessary to add or remove shim washers as required (**Figure 21**).

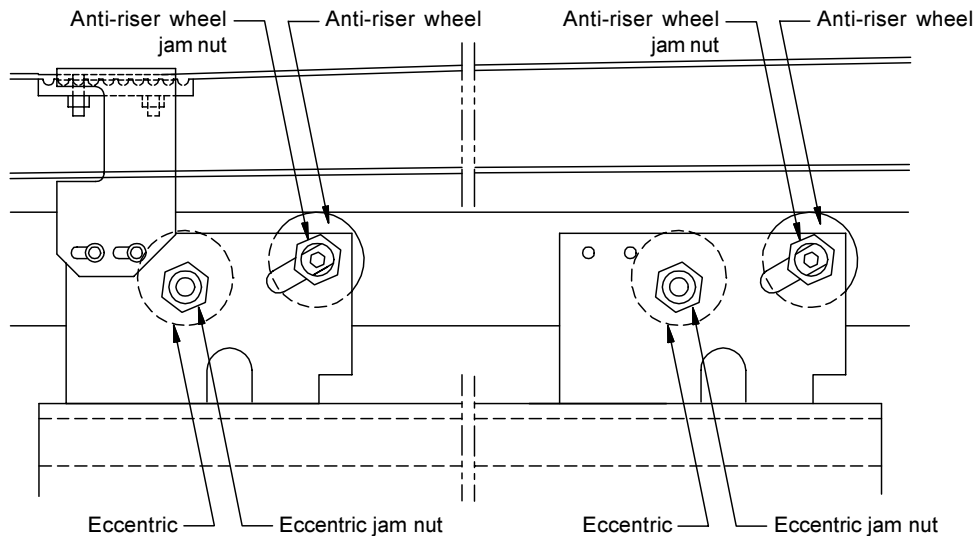


**Figure 21.** Floor Guide Check

## DOOR (SX) INSTALLATION (continued)

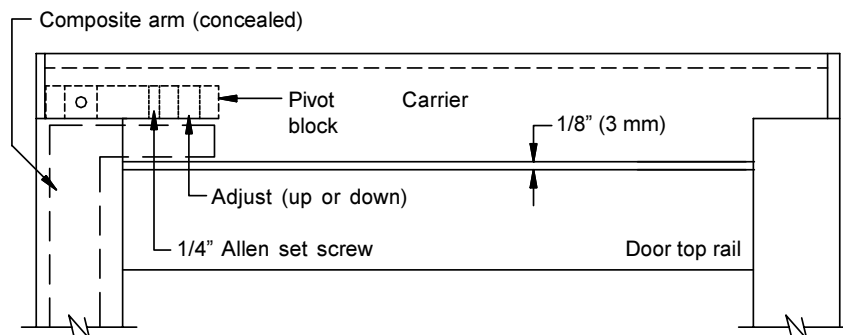
### 6. Adjust door height:

- 6.1. Use a 15/16" wrench to loosen the jam nuts on the eccentrics (**Figure 22**).
- 6.2. Use a 5/16" Allen wrench to rotate eccentrics for a 5/16" (8 mm) gap between bottom of door and threshold. Snug the jam nut to finger tight, then rotate 30 degrees further with a 15/16" wrench for final tightening.
- 6.3. Slide anti-riser wheel up for 1/32" clearance between top of anti-riser wheel and top track. Snug anti-riser wheel jam nuts to finger tight, then rotate 30 degrees further with a 15/16" wrench for final tightening.



**Figure 22.** Adjust Anti-Riser Wheel Clearance

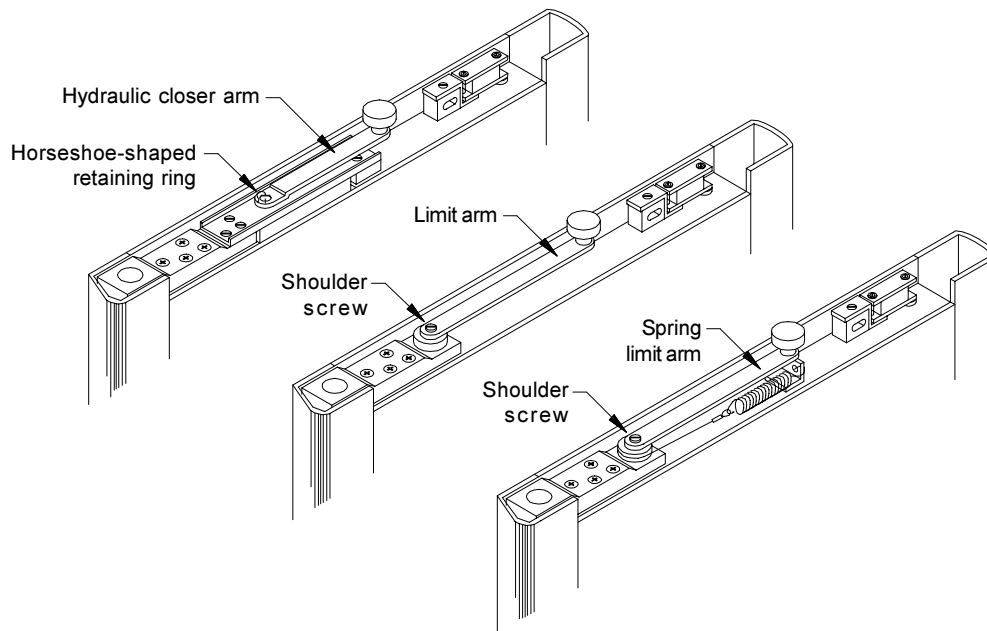
7. Attach the belt bracket to the roller assembly on the lock stile of the door using two (2) M6 serrated flange screws.
8. Next, break open the door and panel. Slowly close the door and check the clearance between the top of the door and the bottom of the carrier. If the clearance is not 1/8" (3 mm), loosen the 1/4" (6 mm) Allen head set screw at the bottom of the carrier. Adjust the clearances as required by turning the large Allen head bolt. After setting the correct clearance, retighten the 1/4" (6 mm) Allen head set screw (**Figure 23**).



**Figure 23.** Door/Carrier Adjustment

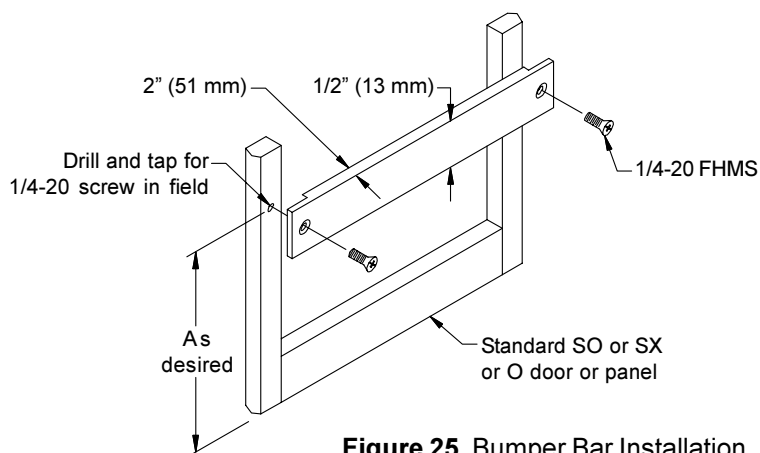
## LIMIT ARM AND BUMPER BAR INSTALLATION

1. Depending on the specific package ordered, Dor-O-Matic provides one of three limit arm types: hydraulic closer arm, limit arm, and spring limit arm (**Figure 24**).
  - 1.1. If the package has a hydraulic closer in the panel, the arm is shipped installed on the closer. Remove the arm by removing the horseshoe-shaped retaining clip from the closer shaft. Install the roller end of the arm into the header extension through the access slot provided. Turn the closer speed adjusting screws to the fully closed position. With a wrench, turn the closer pinion shaft so the slot in the arm will easily slip over the shaft when the door is set in the opening. Re-install the horseshoe-shaped clip through the closer shaft.
  - 1.2. For all other packages, remove the shoulder screw from the limit arm, insert the roller up into the header extension through the circular cutout, and re-install the shoulder screw.



**Figure 24.** Limit Arm Details

2. Refer to **Figure 25** for optional Dor-O-Matic bumper bar installation.



**Figure 25.** Bumper Bar Installation

### NOTES

1. One bar per door.
2. 1/2" (13 mm) max. glass thickness.

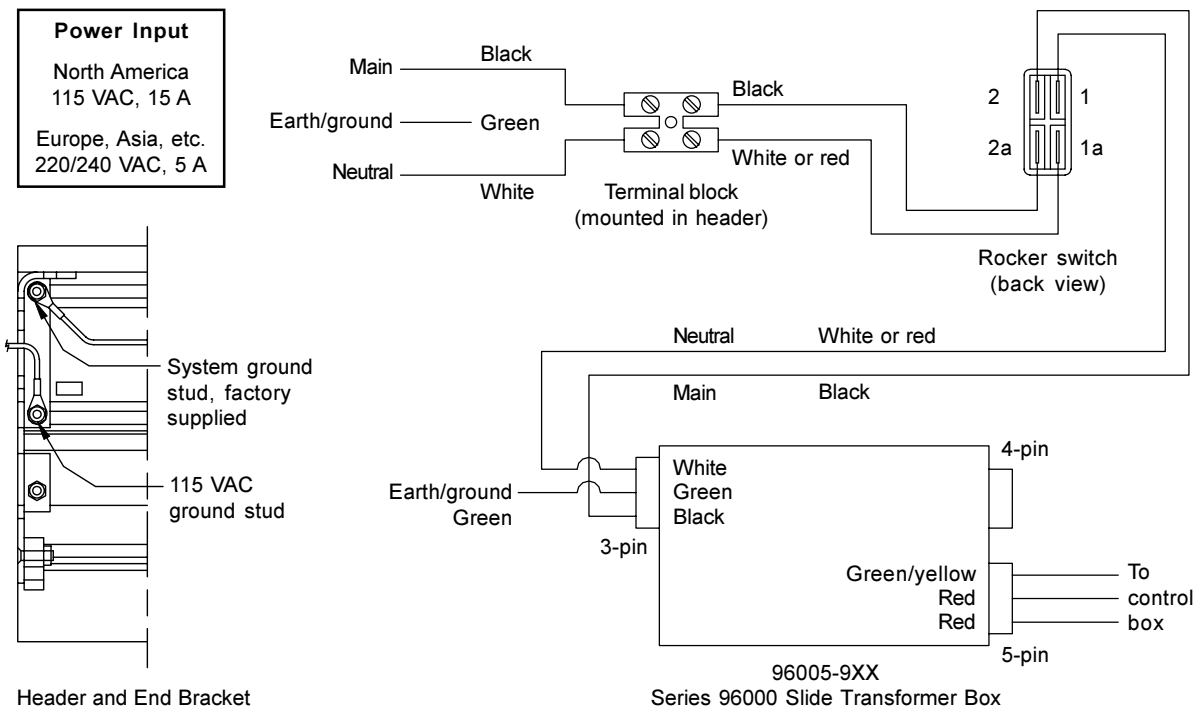
## WIRING DIAGRAM

Refer to **Figure 26** for Series 96000 Slide power connection requirements.



### NOTES

1. Field prepped wire access holes cannot be larger than 1/2" diameter.
2. The ground wire for incoming 115 VAC and the system ground wire cannot share the same grounding stud.
3. All earth/ground wires must be grounded to header. Ground wires cannot share the same grounding stud.



**Figure 26.** Power Connection Requirements

## GLAZING

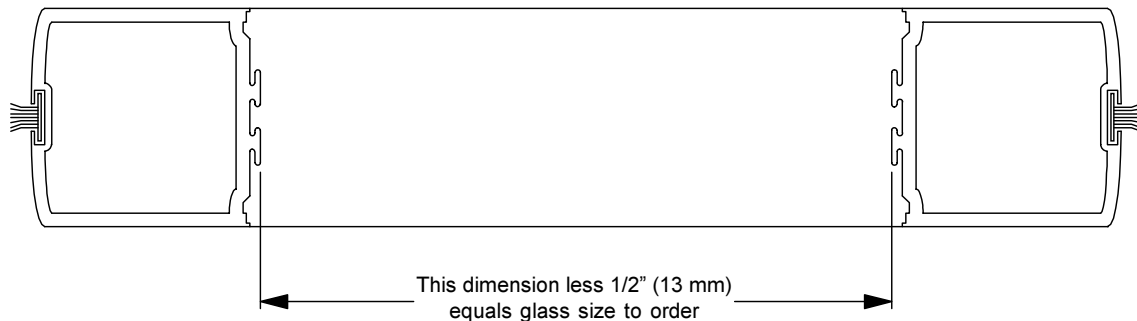
1. Refer to the following chart for maximum weight of door, maximum weight of glass, and maximum glass thickness.

Door/Panel	Max. Weight of Door and Glass*	Max. Glass Thickness
SX Door Inside Slide	150 lbs. (68 kg)	1" (25 mm)
SX Door Outside Slide	150 lbs. (68 kg)	1" (25 mm)
SO Swing Out Panel	200 lbs. (90 kg)	5/8" (16 mm)
O Fixed Panel	200 lbs. (90 kg)	1" (25 mm)
X Sliding Door	200 lbs. (90 kg)	1" (25 mm)
Transom	Varies	1/4" to 1" (6 mm to 25 mm)

\* The average weight of a 42" (1067 mm) door or panel without glass is 40 lbs. (18 kg).

## GLAZING (continued)

- Tempered or laminated glass is required in doors and panels per ANSI Z97.1-1972.
- If the installation is a “standard package,” the glass sizes both with and without 2” (51 mm) muntins are called out in the Dor-O-Matic details and specifications book, along with the model number of the package.
- If the installation is **not** a standard package, measure the width and height between the stile extrusions and **subtract 1/2” (13 mm) (Figure 27)**. This is the glass size to order.
- Order the correct glass stops for the thickness of glass in the application.
- All final opening and closing speed adjustments should be made after the glass is installed.
- Transom glass is measured in the field and can be 1/4” (6 mm) to 1” (25 mm) thick non-tempered glass. Use one or two transom hanger tubes for packages over 10’ 0” (3048 mm) wide to prevent header deflection.



**Figure 27.** Glass Measurement

2. A feature unique to Dor-O-Matic is the “Security Glazing System.” When glazing the doors and panels, snap in two horizontal and two vertical exterior glazing stops. Be sure the stops are securely snapped into the rails and stiles. Place the bottom of the glass onto the nylon glazing blocks and tilt up into vertical position. Have a helper hold the glass in place, and proceed to snap-in the interior glazing stops. This design makes the glass non-removable from the exterior. Finally, check that the rubber trim of the glazing stops is not pinched or tucked against the glass. Run a pocketknife or small scraper around the perimeter of the glass to correct any such problems.

## RELEASE FOR SERVICE

Clean the glass. Install all safety, traffic control, and instruction decals on the door as required. **This is very important! Failure to do this leaves the installer LIABLE for any accident that might occur. This must be done!** Present the keys to the owner or general contractor. Demonstrate the unit; review all safety features as well as the safety check that is to be performed by the owner each morning.



### IMPORTANT

Install all safety, traffic control, and instruction decals on the door as required.