



74600-900 Motion Detector

Installation Instructions

DOR - O - MATIC®

7350 W. Wilson Ave.
Harwood Heights, IL 60656

Toll Free: 1-800-543-4635
In Illinois: 708-867-7400
Sales FAX: 708-867-0291
www.doromatic.com

INSTALLING THE SENSOR:

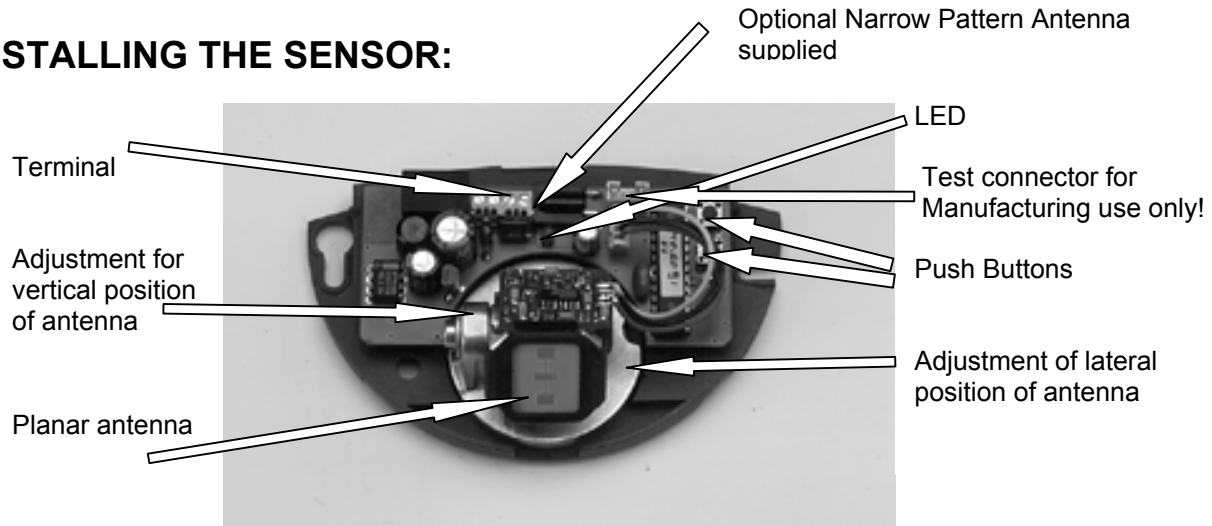

1. Remove the cover from the sensor by holding the sensor firmly and gently prying the cover off as shown below.

Before installation:

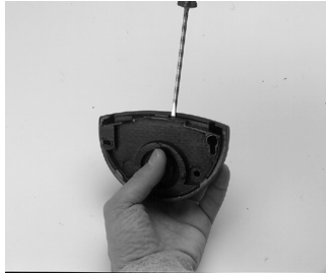

After installation:



2. Stick the mounting template onto the location where the sensor is to be mounted. Follow the directions provided on the template. When drilling is complete, install both screws part way only.

The 74600-900 can be installed on the door header or the ceiling without needing an adapter. If the 74600-900 is mounted on the ceiling, the spherical part of the sensor must face in the opposite direction of the door and an angle of approximately 60° is chosen for the antenna.

Door header

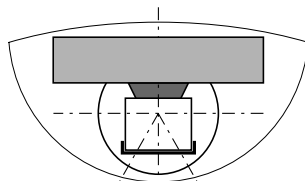

3. Install the cable (included in box). Note: If mounted directly to the header, pull the cable through the hole on the face of the header. Run the cable through the hole provided on the back of the 74600-900, making sure to leave enough cable to reach the terminal block located at the top of the sensor. Position the sensor and tighten the two screws.

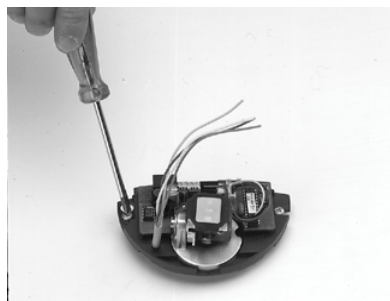
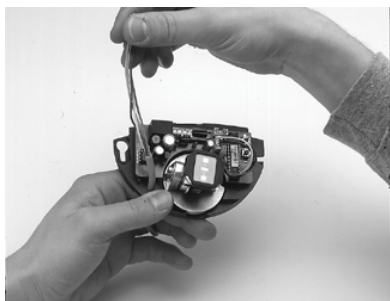

4. Connect the wires to the terminal strip as shown below:
The LED flashes for a few seconds when the unit is started up and flashes continuously during configuration. The LED then lights up when the sensor detects motion.

Terminals:

#1 = 12 to 24 V AC/DC

#2 = 12 to 24 V AC/DC

#3 = Common

#4 = N.O. or N.C.

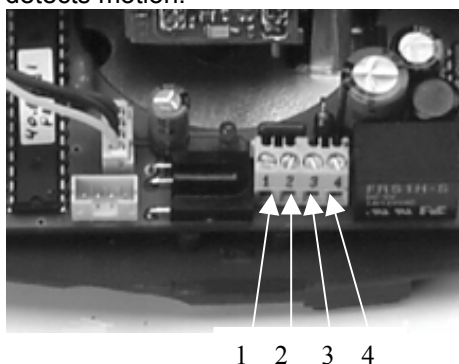

ADJUSTMENTS:

1. **PATTERN SELECTION** - The 74600-900 comes factory preset with the wide planar antenna installed and a sensitivity setting of 7 (0 min – 9 max). In most applications, the Wide Planar Antenna will not need to be changed but the angle and sensitivity can be adjusted to customize the sensor for the particular installation. If necessary, the additional optional Narrow Pattern Antenna comes neatly packaged inside the 74600-900 Sensor.

- A. The width of the detection zone is determined by the choice of the planar antenna. When installing the planar antenna make sure to mount the antenna with the elements facing out and oriented vertically as shown below.

Wide Pattern = 3 elements

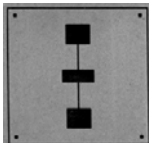

Narrow Pattern = 6 elements

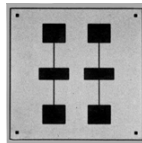

- B. Sensing Fields according to type of antenna.

Vertical angle = 30°
Sensitivity = 9
Mounting height = 7'2"

3-element

6-element

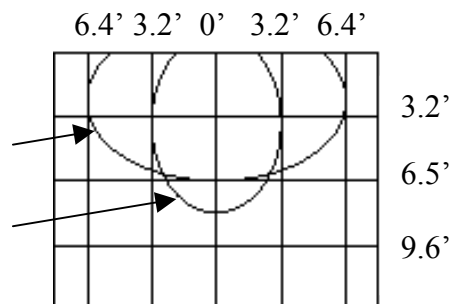

- C. Carefully remove the protective cover of the planar antenna by gently snapping it off the cell. Next, change the antenna making sure to place the planar antenna in the groove on the cell. Once the planar antenna is positioned correctly, gently snap the protective cover over the antenna and cell.



2. VERTICAL ANGLE SELECTION

HEADER MOUNT: When installing the 74600-900 on the header, mount it at least 2 inches from the bottom of the header. In fact, the higher on the header the better.

- A. To achieve detection as close to the door as possible: Tilt angle of antenna must be set at minimum (0°).

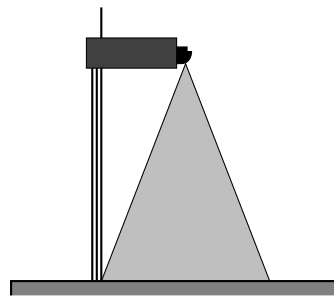
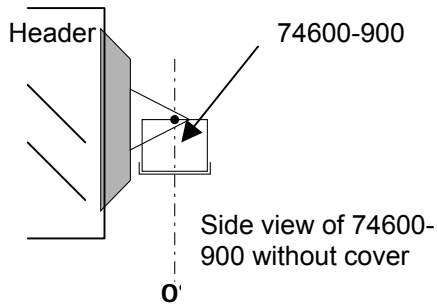

- B. To achieve detection close to the door: Tilt angle of antenna must be set between 0° and 20° .

- C. To achieve detection far from the door: Tilt angle of antenna must be set at the maximum (45°)

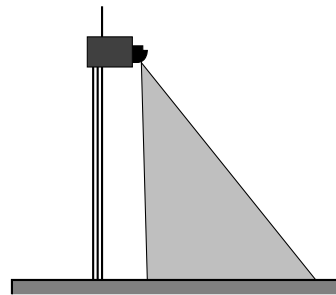
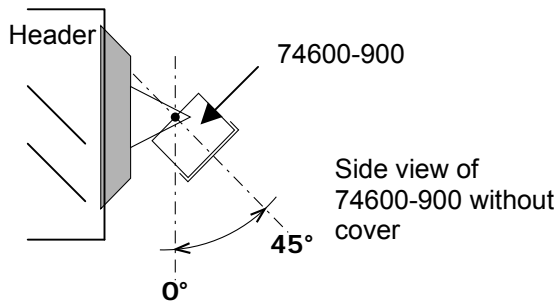

- D. Detection pattern according to the vertical tilt angle of the antenna.

Sensitivity = 9
Mounting height = 7'2"

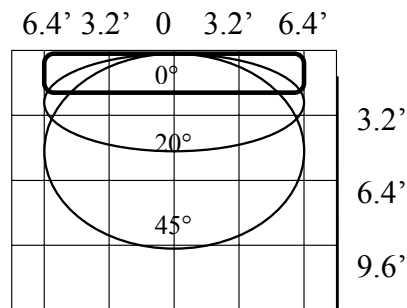

3-element antenna (wide pattern)

CEILING MOUNT:

- A. Ceiling Mount detection: Tilt angle of the antenna must be set at the maximum position of $70^\circ - 75^\circ$ and the spherical part of the sensor must be positioned away from the door.

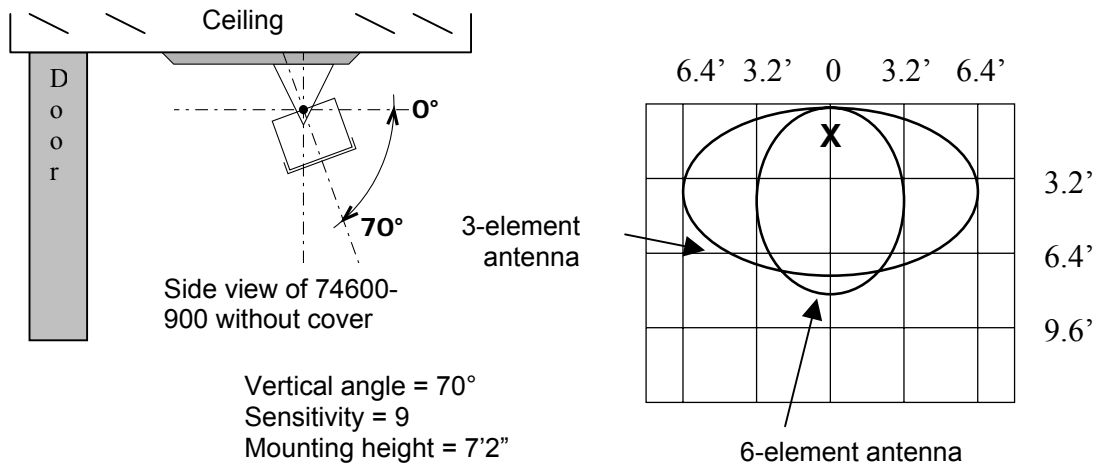

3. LATERAL ANGLE SELECTION

The lateral position of the sensing field in front of the door is determined by the lateral tilt angle of the antenna.

Top view of 74600-900 without cover.

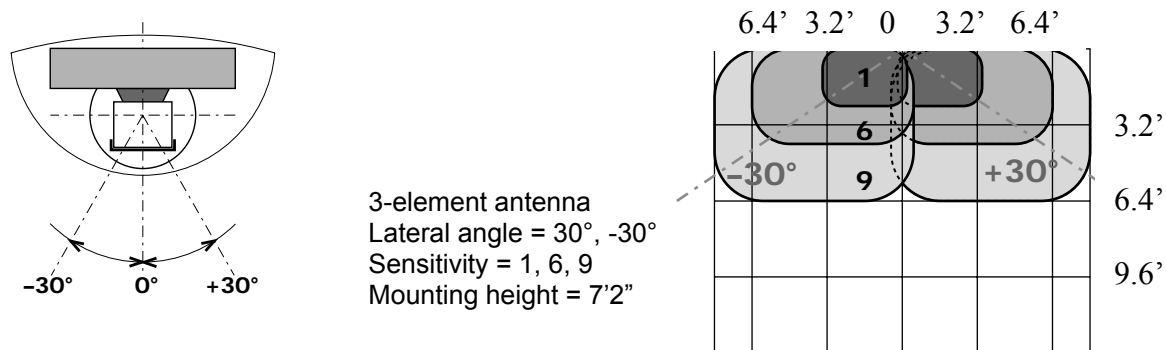

4. SENSITIVITY SELECTION

The pattern size depends on the sensitivity setting and the mounting height of the sensor.

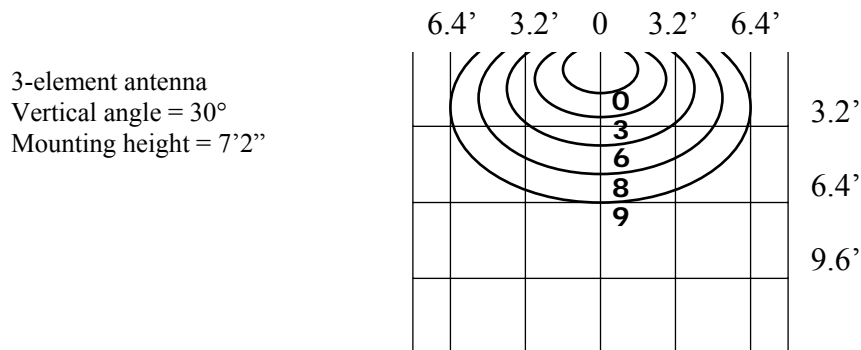

REMOTE CONTROL CONFIGURATION:

For optimum results, point the remote control directly at the sensor before you press the buttons. The remote control has an operation range of approximately 15ft and can adjust the sensor with or without its cover on.

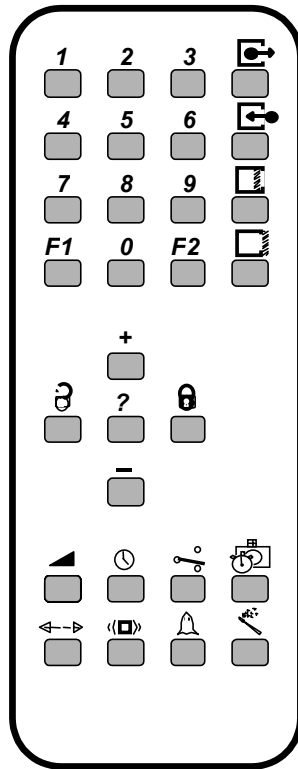









MOTION TRACKING FEATURE (MTF) - The motion tracking feature is available when the 74600-900 is used in Unidirectional mode. The 74600-900 is factory preset with the MTF off. To select the MTF, press the function button followed by the number 3.

- UNIDIRECTIONAL MODE: detecting only motion moving toward the sensor.

OR

- UNIDIRECTIONAL MODE WITH MTF: **The principle is as follows:**
 - The detector does NOT activate its relay as long as it detects movement exclusively moving away from the detector. It acts like the classic unidirectional detector.
 - As soon as the 74600-900 detects movement toward the sensor, it automatically switches to bi-directional mode.
 - It maintains this bi-directional function for approximately 2 seconds following the last detection of motion toward the door.
 - At the end of this time, if it does not detect any further motion, it switches back to the unidirectional mode.

Function Key	Actions	Factory Settings	LED Status
	UNLOCK – Press this key followed by your 4-digit access code. When the access code is reset to the factory value (0000) you can access adjustment mode directly without the need to re-enter this code.	0000	LED flashes slowly to indicate an adjustment session is under way.
	SENSITIVITY – Press this key followed by the number button (0-9) of the sensitivity desired. 9 – maximum 0 - minimum	7	LED flashes more rapidly while the unit waits for the numerical input. It then continues to flash more slowly.
	HOLD TIME – Press this key followed by the number button (0-9) to enter the required hold time. 0- 0.5 sec. 4- 4 sec. 7- 7 sec. 1- 1 sec. 5- 5 sec. 8- 8 sec. 2- 2 sec. 6- 6 sec. 9- 9 sec. 3- 3 sec.	0.5 sec.	LED flashes more rapidly while the unit waits for the numerical input. It then continues to flash more slowly.
	DETECTION MODE – Press this key followed by a number button (1-3) to select the required mode. 1- bi-directional mode 2- unidirectional mode 3- unidirectional mode with MTF*	Uni-directional	LED flashes more rapidly while the unit waits for the numerical input. It then continues to flash more slowly.
	RELAY CONFIGURATION - Press this key followed by a number button (1-4) to select the required relay output desired. 1- passive output , relay contact closed during detection, open during non-detection 2- active output , relay contact open during detection, closed during non-detection 3- continuous detection , relay contact always closed 4- continuous non-detection , relay contact always open	Passive	LED flashes more rapidly while the unit waits for the numerical input. It then continues to flash more slowly.
	IMMUNITY – Press this key followed by a number button (1-3) to select the type of detection desired. 1- extreme sensitivity 2- normal sensitivity 3- decreased sensitivity (rain, vibrations, etc.)	Normal	LED flashes more rapidly while the unit waits for the numerical input. It then continues to flash more slowly.
	LOCK – When all the parameters have been recorded, press this button to lock settings. 1- If you wish to enter a new access code , the number keys (0-9) to enter the new 4-digit code within 10 seconds. The 4-digit code must begin with the number 1. 2- If you want to keep the current access code , press the LOCK button a second time.	0000	The LED stops flashing to return to its normal function.
	INQUIRY – Press this button after pressing the button of the parameter that you would like to check. Then count the number of times the LED flashes. This corresponds to the status of the parameter in question.	No setting	The LED will flash. Count the number of times the LED flashes. This corresponds to the status of the parameter in question.
	DEFAULT VALUE – Press this button followed by the number 1. All the parameters are reset to the preset factory values.	No setting	

MANUAL CONFIGURATION:

If you do not have a remote control, you can adjust the sensitivity parameter ONLY, by means of the push buttons + and —.

The sensor parameters that are not accessible manually will remain at the factory preset values. The default values may be restored by pressing the two push buttons, located on the circuit board, simultaneously for at least two seconds.

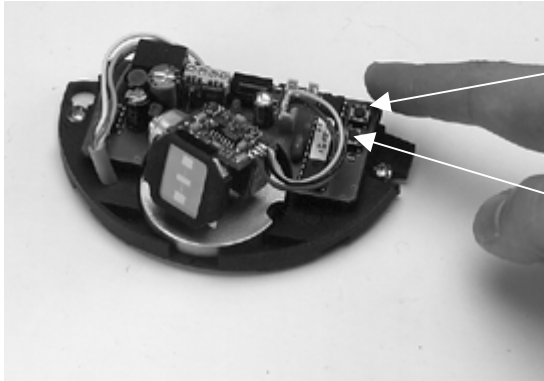

+ Press to increase sensitivity by one unit

— Press to decrease sensitivity by one unit.

TROUBLE SHOOTING:

SYMPTOM	CORRECTIVE ACTION
The door will not open & LED does not light up	<ol style="list-style-type: none"> 1. Check supply 2. Check supply voltage 3. Check power connector
The sensor does not respond to the remote control	<ol style="list-style-type: none"> 1. Check battery insertion 2. Check battery voltage
The sensor does not respond to the code entered with the remote control	Remove the cover and press the 2 buttons simultaneously for at least two seconds. This will reset the lock code to 0000. Then press the unlock button to enable you to access the settings with the remote control.
The door open and closes constantly	<ol style="list-style-type: none"> 1. Increase the tilt angle of the antenna 2. Reduce sensitivity

If after troubleshooting a problem, a satisfactory solution cannot be achieved, please call Dor-O-Matic for further assistance.

DO NOT leave any problem unresolved. If you must wait for the following workday, leave the door inoperable until satisfactory repairs can be made.
NEVER sacrifice the safe operation of the automatic door or gate for an incomplete solution.