

## 1 Description

The Door Sequencer II (8310-849) is a programmable relay module that may be used for multiple applications. The module provides removable screw terminal connectors, and easy 2-button digital programming with a user-friendly display. The Door Sequencer II product line is identified by a blue translucent housing. Check the label on the housing for the exact Door Sequencer model. See Table for defined functions.

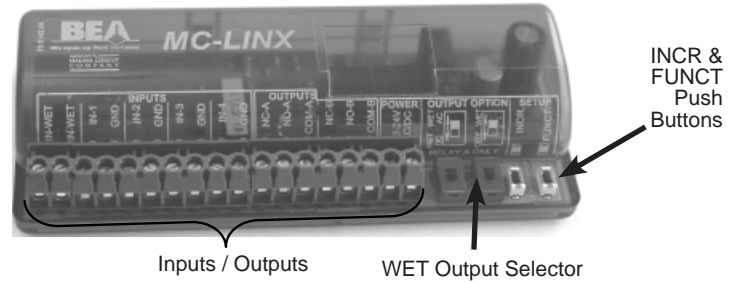

DOOR SEQUENCER II

FUNCTION	EXPLANATION	DESCRIPTION
50	Interlock Module	This module will accept two inputs, and will disallow input 1 while input 2 is active, and disallow input 2 while input 1 is active. Input 1 provides output to Relay A and input 2 provides an output to Relay B.
55	Interlock Module	Provides an interlocking ratchet relay function, whereby Relay A is allowed to Ratchet only if the door position switch input from Relay B is closed and vice-a-versa for Relay B.
65	Sequencer Module	Four inputs will be accepted: Input 1 triggers a sequenced output in which relay A is held on by the time specified in variable $hA$ , then a delay specified by variable $d1$ , then relay B is held for a delay specified by $hB$ . Input 2 triggers a sequenced output in which relay B is held on by the time specified in variable $hB$ , then a delay specified by variable $d2$ , then relay A is held for a delay specified by $hA$ . Input 3 triggers relay A for a hold time specified by $hA$ , and Input 4 triggers relay B for a hold time specified by $hB$ . Each time delay can be set from 0 to 60 secs.
75	Wet Input Module	Same as function 25, but with the added ability to accept a 'WET' input from the triggering device. This input is next to Input 1 at the module. A wet input can be AC or DC, and can accept 12 to 24 volts +/- 10%.

## 2 Specifications

DESCRIPTION	SPECIFICATION
Supply Voltage	12 to 24 VAC/VDC: +/- 10%
Mains Frequency	50/60 Hz
Power Consumption	50mA max. (triggered and with no load)
Temperature Range	-4°F to +131°F
Dimensions	5.2" (133mm) W x 2.2" (55mm) D x 1" (25mm) H
Housing Material	Polycarbonate – Blue Translucent
Input Specification	Dry contact input only, except for Function 75 Wet Input: 12 to 24 VAC/VDC: +/- 10%
Output Specification	Relay Rating : Max. switching voltage: 125 VAC, 60VDC Max. switching current: 1A Max. switching power: 62.5VA, 30W
'WET' Output (at Relay A only)	See Section 3 Pre-Installation Tips

## 3 Precautions



- ❑ Shut off all power going to header before attempting any wiring procedures.
- ❑ Maintain a clean & safe environment when working in public areas.
- ❑ Constantly be aware of pedestrian traffic around the door area.
- ❑ Always stop pedestrian traffic through the doorway when performing tests that may result in unexpected reactions by the door.
- ❑ ESD electrostatic discharge: Circuit boards are vulnerable to damage by electrostatic discharge. Before handling any board ensure you dissipate your body's charge.
- ❑ Always check placement of all wiring before powering up to insure that moving door parts will not catch any wires and cause damage to equipment.
- ❑ Ensure compliance with all applicable safety standards (i.e. ANSI A156.10 / A156.19) upon completion of installation.
- ❑ When preparing to wire multiple devices together for a 'system' configuration, it is best to ensure the correct operation of each device independently before starting to help reduce troubleshooting time later, in the event of a discrepancy.
- ❑ When applying equipment on a new installation, utilizing new electrical supply circuits, always ensure that correct line voltage exists and is stable. Remember to shut the power back off once this is checked, before performing any wiring to the system.
- ❑ DO NOT attempt any internal repair of the sensor. All repairs and/or component replacements must be performed by LCN Inc. Unauthorized disassembly or repair:
  1. May jeopardize personal safety and may expose one to the risk of electrical shock.
  2. May adversely affect the safe and reliable performance of the product will result in a voided product warranty.

### PRECAUTIONS TO OBSERVE WHEN USING A 'WET' OUTPUT

- ❑ Never change the switch settings when the module has power connected to it or when a load is applied.
- ❑ Never allow 2 different voltage sources to be connected to the load (electric strike for example) at the same time. This can result in serious damage to equipment.
- ❑ If a device is normally being powered by a separate power source, DO NOT select the 'Wet' output option on the Door Sequencer. If 'Wet' is selected, the next activation of the module will send a voltage to the load and if there is already a voltage being applied from another source, the Door Sequencer and possibly the load will be permanently damaged.
- ❑ When using the 'Wet' output option on the Door Sequencer, set all desired switch positions (Wet – Dry and AC – DC) before the module is powered and before any loads are applied.
- ❑ Ensure there is no other voltage connected to the load. Whatever the input voltage is at the Door Sequencer, the output will correspond. The following can also be observed:
  1. If voltage input at the Door Sequencer is AC, then output selection can be AC or DC
  2. If voltage input at the Door Sequencer is DC, then output selection can only be DC
  3. The maximum load applied to Output A should never exceed 1A. If more than one device is to be connected, add the consumption values together for a total value. If current is excessive, damage to equipment can result.
  4. On the Door Sequencer, the 'Wet' output is only available at Output A.

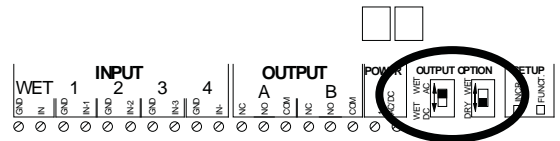

## 4 Programming Guide

1. The following are general notes that must be observed while programming for any of the functions available within the Door Sequencer II:
  - A. When there is no function set, as is the case on an initial power on, the user must first press and hold both push buttons (INCR & FUNCT) for three (3) seconds to activate the display. At this point the display will toggle between FF and 00 every two (2) seconds for ten (10) seconds overall.
  - B. FF signals the function that is active and 00 shows that no function is active.
  - C. By pressing on the INCR button, the user can toggle through each function. A setting of 00 disables the module, and there are no functions or values active.
  - D. A display of 50 corresponds to Function 50, 75 corresponds to Function 75 and so on. The LE21 function is indicated by a 21.
  - E. After pressing the INCR push button to select the function, the user can then press the FUNCT button to set the variables defined for that particular function.
  - F. Once the FUNCT button has been pressed, as to enter into the respective sub-functions & values, the User will not be able to go back and select a different module designation until the display goes inactive, and the user repeats the above process. This prevents the User from inadvertently selecting variables from different functions.
  - G. Note also that when a User holds both push buttons for three seconds, the module is reset to 00 and all variables are cleared. However at any time during operation the user can press momentarily on the FUNCT push button and the display will become active. In this way the user can toggle through the variables used only for the module that they have selected. Remember that the INCR push button always increments the value of the variable that you are looking at, and the FUNCT push button toggles through the available variables.
  - H. To begin, identify the function that is required for the application. Now press the FUNCT push button until the desired function appears on the LCD display. Go to the respective section of this manual for setup instructions pursuant to the chosen function.

## 5 Function '5 0' Interlock Module

1. Wire the module according to the diagram.
2. According to the steps outlined in Section 4 – Programming Guide – the function 5 0 should be showing on the display. If not, follow the procedures in Section 4 again, and program the module for function 5 0.
3. Upon activating the module through Input 1, Relay A (Door 1) is triggered. When Door 1 is at a position other than closed, the DPS (Door Position Switch) will be in an open state, thus disallowing the activation of Input 2. The same applies for Door 2 when it is open, thereby disallowing the activation of input 1.
4. Program the module according to the chart.

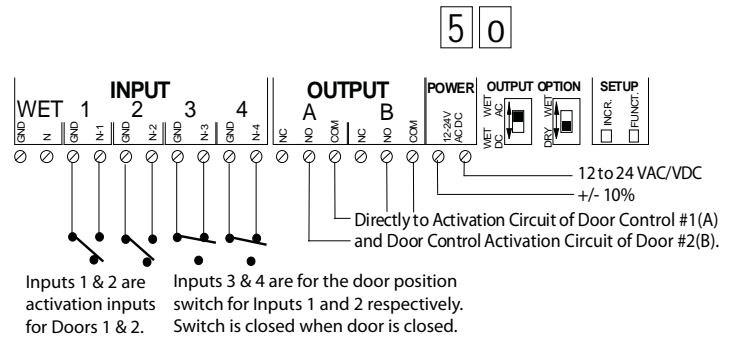

SUB-FUNCTION (FUNCT Button)	DESCRIPTION	POSSIBLE VALUES (INCR Button)
'h R'	Output A hold time	'0 0' through '5 0' seconds
'h b'	Output B hold time	'0 0' through '5 0' seconds

5. Upon completion of the above steps, walk test the door to ensure all functions, timers, sensors, etc. are working as intended, and that the system is in compliance with all applicable standards (ie. ANSI A 156.10, A156.19).

**NOTE:** The door position switches must have a closed contact when the door is closed, and an open contact when it is not.

## 6 Function '5 5' Interlock Ratchet Relay

1. Wire the module according to the diagram.
2. According to the steps outlined in Section 4 – Programming Guide – the function 5 5 should be showing on the display. If not, follow the procedures in Section 4 again, and program the module for function 5 5.
3. Upon activating the module through Input 1, Relay A (Door 1) is triggered. Relay A is held until Input 1 is triggered again. Same applies for Relay B via Input 2. DPS (Door Position Switch) for Door 1 should be tied to Input 3, DPS for Door 2 should be tied to Input 4. Neither relay will be allowed to activate unless the opposite door position switch is closed, indicating closed door allowing an interlock between Relay A & Relay B. Module requires no further program settings.
4. Upon completion of the above steps, walk test the door to ensure all functions, timers, sensors, etc. are working as intended, and that the system is in compliance with all applicable standards (ie. ANSI A 156.10, A156.19).

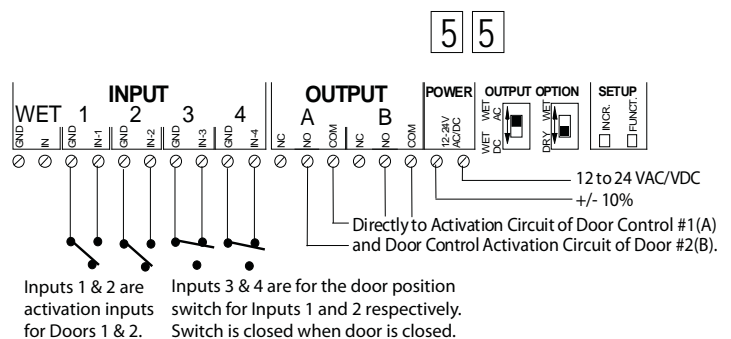

**NOTE:** The door position switches must have a closed contact when the door is closed and an open contact when it is not.

## 7 Function '55' Sequencer Module

1. Wire the module according to the diagram.
2. According to the steps outlined in Section 4 – Programming Guide – the function 5 5 should be showing on the display. If not, follow the procedures in Section 4 again, and program the module for function 5 5.
3. A sequenced operation can be obtained by triggering Input 1 or Input 2. When Input 3 or 4 is triggered, it only activates Door 1 (relay A) or Door 2 (relay B) respectively (for example, for use with vestibule switches for entrapment purposes).
4. Sequence timers will start upon the activation and release of the inputs. A re-activation of the input will re-start the timers and a maintained input will trigger the relays according to the program values, but will hold relay output A & B active until the input is released.
5. Program the module according to the chart:

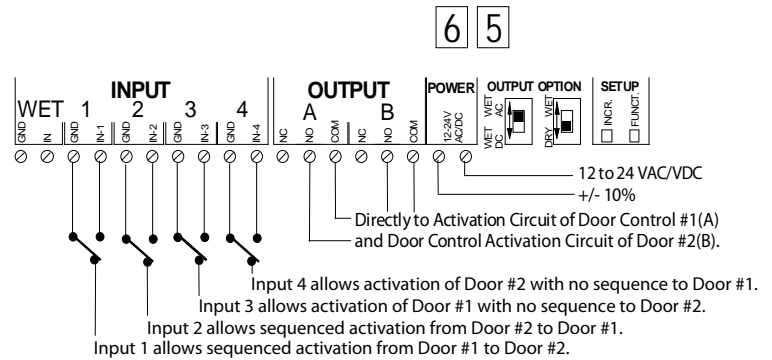

SUB-FUNCTION (FUNCT Button)	DESCRIPTION	POSSIBLE VALUES (INCR Button)
'h A'	Output A (Door 1) hold time	'0 0' through '5 0' seconds
'h B'	Output B (Door 2) hold time	'0 0' through '5 0' seconds
'd 1'	Delay from Output A (Door 1) to Output B (Door 2)	'0 0' through '5 0' seconds
'd 2'	Delay from Output B (Door 2) to Output A (Door 1)	'0 0' through '5 0' seconds

6. Upon completion of the above steps, walk test the door to ensure all functions, timers, sensors, etc. are working as intended and that the system is in compliance with all applicable standards (ie. ANSI A 156.10, A156.19).

## 8 Function '75' Wet Input Module

1. Wire the module according to the diagram shown.
2. According to the steps outlined in Section 4 – Programming Guide – the function 7 5 should be showing on the display. If not, follow the procedures in Section 4 again, and program the module for function 7 5.
3. Once programming is complete, trigger the module via the 'Wet' input. Ensure that Relay A and Relay B outputs are functioning according to the programming. When the module is triggered, an 'r A' or 'r B' will appear in the display. This indicates that the respective relay is energized.
4. Sequence timers will start upon the activation and release of the inputs. A re-activation of the input will re-start the timers, and a maintained input will hold the relays active. Once Input is released, Relay A & B hold time will count down normally.
5. Be sure to set the 'Output Option' dipswitches to their correct position. The output voltage is equal to the input voltage. If AC is input, then AC or DC is available for output. If DC is input, then only DC will be available for output.
6. Program the module according to the chart:

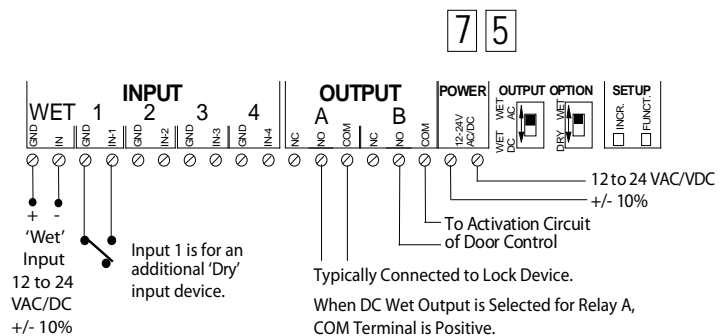

SUB-FUNCTION (FUNCT Button)	DESCRIPTION	POSSIBLE VALUES (INCR Button)
'h A'	Output A hold time	'0 0' through '5 0' seconds
'h B'	Output B hold time	'0 0' through '5 0' seconds
'd'	Delay from Output A to Output B	'0 0' through '5 0' seconds

7. Upon completion of the above steps, walk test the door to ensure all functions, timers, sensors, etc. are working as intended, and that the system is in compliance with all applicable standards (ie. ANSI A 156.10, A156.19)

## 9 Documentation

1. Document all work. For future reference, be sure to record the Door Sequencer II Serial Number on your work order.
2. Educate the Owner / Manager as to the proper operation of the door and sensor system, and what to do to ensure safe use of the door in the event of discovering a malfunction. Show the Owner / Manager how to perform a daily safety check of the system.
3. Be sure to obtain signatures on your work order for all work accomplished.

## 10 Troubleshooting

PROBLEM	PROBABLE CAUSE	CORRECTIVE ACTION
Module will NOT react to any input.	<ol style="list-style-type: none"><li>1. Incorrect power input</li><li>2. Module not programmed</li><li>3. Incorrect wiring</li><li>4. Faulty module</li></ol>	<ol style="list-style-type: none"><li>1. Check input power. Should be 12 to 24 volts AC or DC +/- 10%. Ensure that input power is applied at the correct terminals.</li><li>2. Ensure a function has been programmed. If '- -' is showing in the display, the module will need to be programmed.</li><li>3. Jumper an active input and ensure that the fault is not within the wiring. If module works when jumpered, trace wiring from Inputs / outputs.</li><li>4. Replace module.</li></ol>
Module reacts to input but has no output.	<ol style="list-style-type: none"><li>1. Wrong outputs are connected</li><li>2. Incorrect wiring</li><li>3. Faulty module</li></ol>	<ol style="list-style-type: none"><li>1. Check to ensure that the proper outputs are connected per the function selected.</li><li>2. Trace all wiring to ensure correct termination points</li><li>3. Replace module</li></ol>

## 11 Company Contact

**LCN**<sup>®</sup>



Do not leave problems unresolved. If a satisfactory solution cannot be achieved after troubleshooting a problem, please contact LCN at 1-800-526-2400. If you must wait for the following workday to call LCN, leave the door inoperable until satisfactory repairs can be made. Never sacrifice the safe operation of the automatic door or gate for an incomplete solution.

For more information, visit [www.lcn.ingersollrand.com](http://www.lcn.ingersollrand.com).