

### 1 Description

The Time Delay Module (8310-845) is a Delay on Make / Delay on Break Time Delay Relay Module. It is perfect to use when either a magnetic lock or electric strike is installed on an automatic door. The delay on break timer will release the lock and then the delay on make timer will enable the door to open and be held open for a set period of time.

When a momentary contact closure is applied at the input wires, RELAY 1 ( 0-7 seconds) will become active. Approximately 0.5 or 1.5 seconds after RELAY 1 becomes active, a second relay, RELAY 2, ( 0-15 seconds ) will become active. The time delay will begin as soon as the input signal is released. If another momentary contact closure is applied to the input wires during the output of RELAY 2, the entire timing cycle will begin again. RELAY 2 will not drop out, but it will be reset to the full time delay. Also, the input voltage can be supplied through the contacts of RELAY 1 by changing the position of two jumpers on the Time Delay Module.



### 2 Specifications

| DESCRIPTION                      | SPECIFICATION                  |
|----------------------------------|--------------------------------|
| Supply Voltage                   | 15 to 24 VAC/VDC: - 5% to +10% |
| Operating Frequency              | 4 MHz (Microprocessor)         |
| Power Consumption                | 10mA at rest, 50 mA max.       |
| Output                           | (2) SPDT Relays                |
| Maximum Voltage - Relay Contact  | 30V DC, 120V AC                |
| Maximum Current - Relay Contacts | 1.0A DC, 0.5A AC               |

### 3 Precautions



- Shut off all power before attempting any wiring procedures.
- Maintain a clean & safe environment when working in public areas.
- Constantly be aware of pedestrian traffic around the door area.
- Always stop pedestrian traffic through the doorway when performing tests that may result in unexpected reactions by the door.
- ESD electrostatic discharge: Circuit boards are vulnerable to damage by electrostatic discharge. Before handling any board ensure you dissipate your body's charge.
- Always check placement of all wiring before powering up to insure that moving door parts will not catch any wires and cause damage to equipment.
- Ensure compliance with all applicable safety standards (i.e. ANSI A156.10 / A156.19) upon completion of installation.
- When preparing to wire multiple devices together for a 'system' configuration, it is best to ensure the correct operation of each device independently before starting to help reduce troubleshooting time later, in the event of a discrepancy.
- When applying equipment on a new installation, utilizing new electrical supply circuits, always ensure that correct line voltage exists and is stable. Remember to shut the power back off once this is checked, before performing any wiring to the system.
- DO NOT attempt any internal repair of the sensor. All repairs and/or component replacements must be performed by LCN Inc. Unauthorized disassembly or repair:
  1. May jeopardize personal safety and may expose one to the risk of electrical shock.
  2. May adversely affect the safe and reliable performance of the product will result in a voided product warranty.

## 4 Wiring

| COLOR  | DESCRIPTION                                |
|--------|--------------------------------------------|
| Orange | + Power (15-24 VAC/VDC)                    |
| Brown  | - Power (15-24 VAC/VDC)                    |
| Gray * | COM (Input Contact from Activation Device) |
| Gray * | NO (Input Contact from Activation Device)  |
| Violet | RELAY 1 NC Contact                         |
| Red    | RELAY 1 COM Contact                        |
| Black  | RELAY 1 NO Contact                         |
| Green  | RELAY 2 NC Contact                         |
| Yellow | RELAY 2 COM Contact                        |
| Blue   | RELAY 2 NO Contact                         |

\* - Gray wires must be connected to Dry Contacts Only

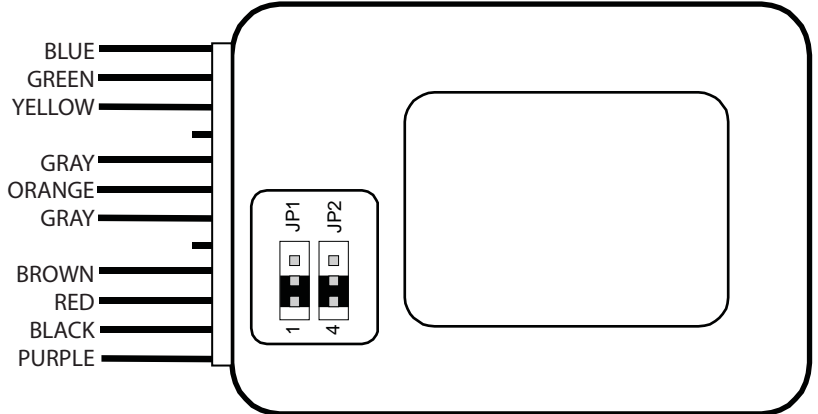

## 5 Electrical Installation

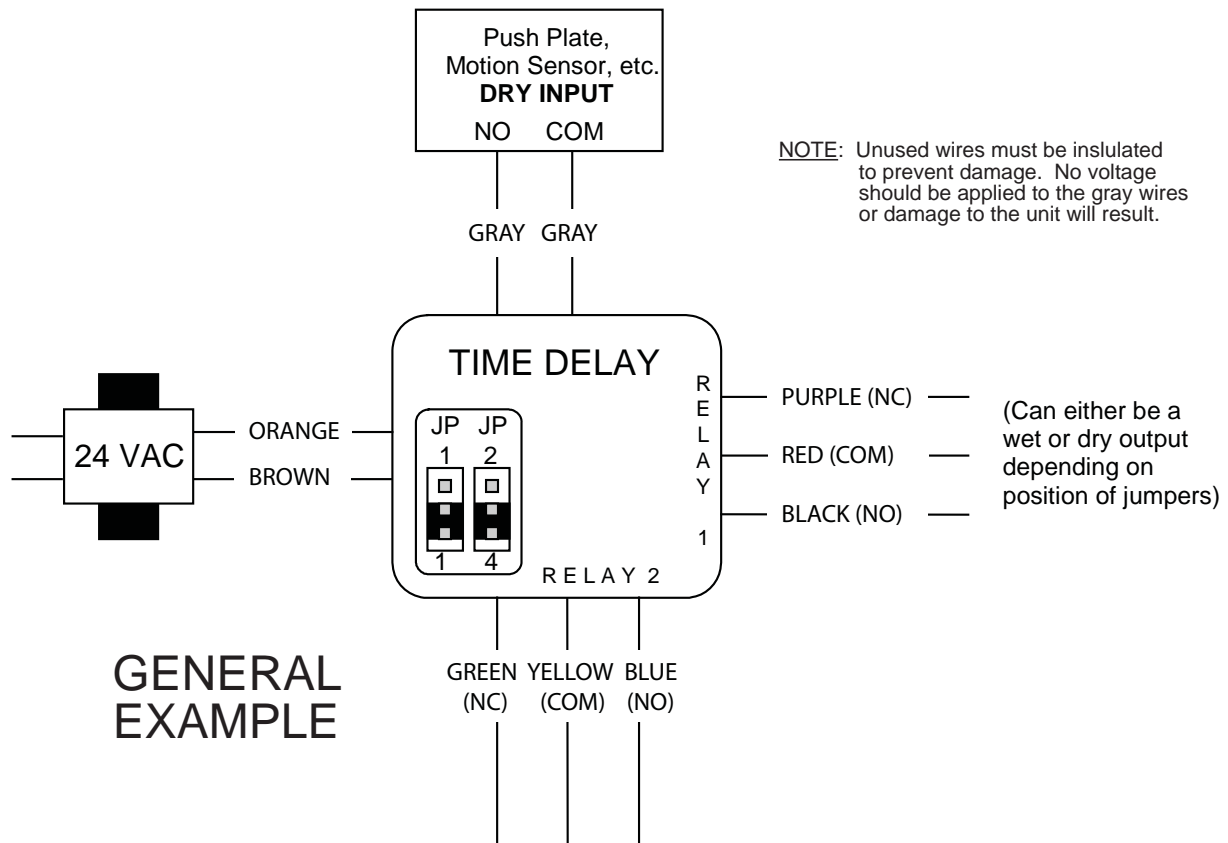

## 5 Electrical Installation (cont'd)

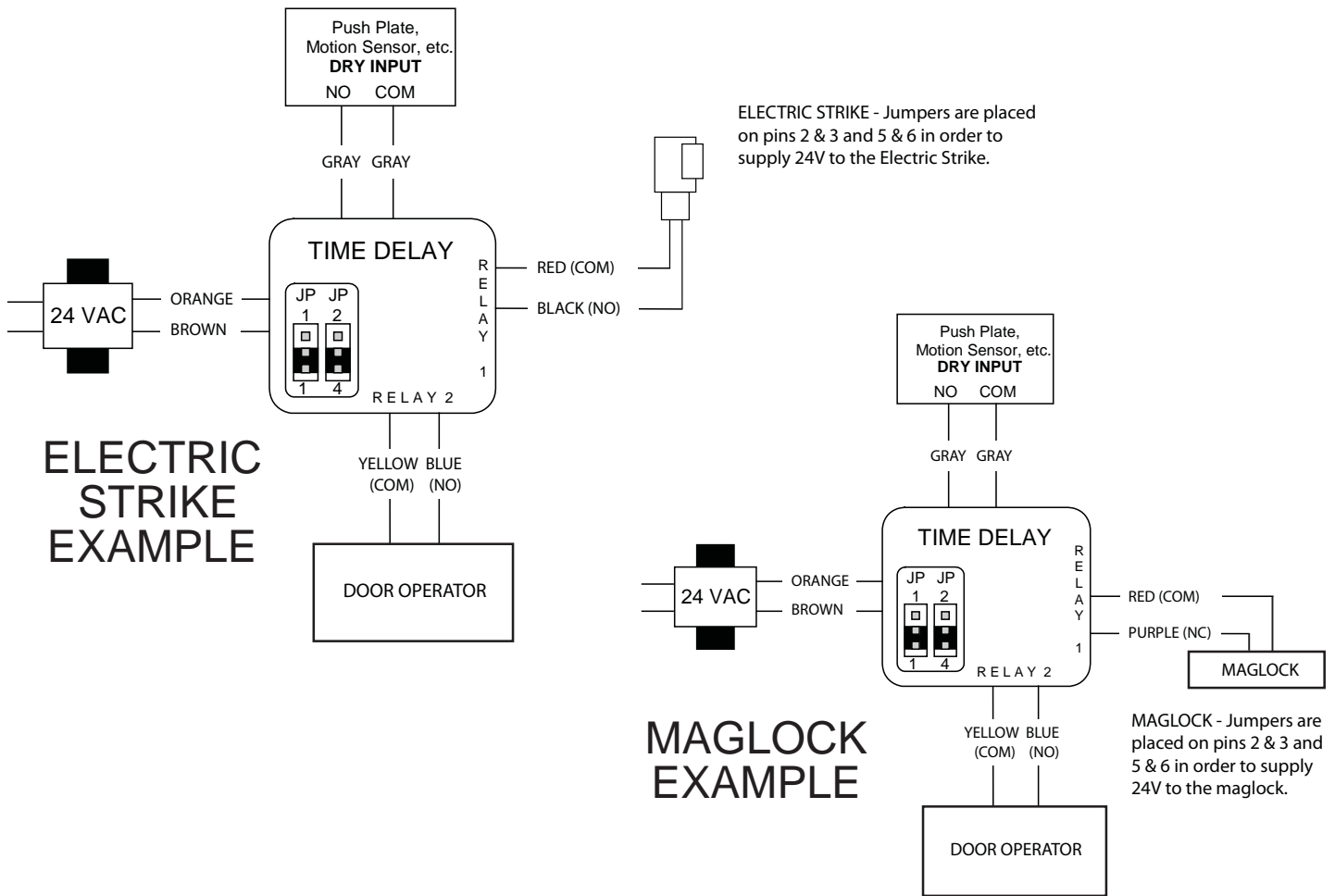

## 6 Module Settings

### 1 Jumpers

The jumpers on the time delay provide the installer the flexibility of either a dry output or a wet output at RELAY 1. If both jumpers are on the left and middle pins (1 & 2 and 4 & 5) RELAY 1's output (NO, NC and COM) is a dry output; therefore, there is no voltage or current supplied by the time delay. If a voltage is required at the output of RELAY 1, both jumpers must be moved to the middle and right pins (2 & 3 and 5 & 6). This configuration will enable the time delay module to supply a voltage at RELAY 1's output (NO, NC and COM). The supplied voltage will equal the input voltage. For example, if the input voltage is 24 VAC the output voltage will be 24 VAC or if the input voltage is 15 VDC the output voltage is 15 VDC.

**NOTE:** If the jumpers are placed diagonal from each other the time delay module will not function correctly.

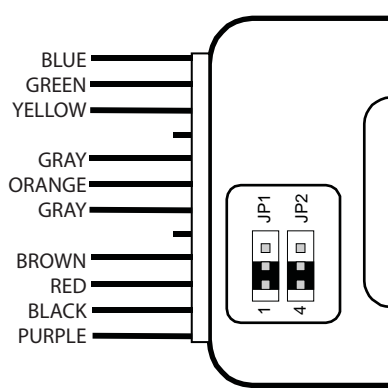

DRY OUTPUT ON RELAY 1

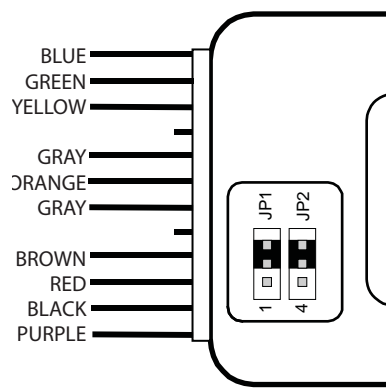

WET OUTPUT ON RELAY 1

## 2 Dipswitch

Set the dipswitches according to the charts below to achieve the desired hold open time delay.

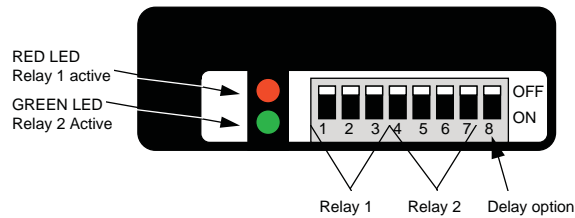

### RELAY 1

The time delay on RELAY 1 is adjustable from 0 to 7 seconds by setting Dip Switches 1, 2, & 3 according to the chart. The Red LED will be on for the duration of the time delay set on RELAY 1. Independent of the time delay set on RELAY 1, RELAY 2 will be activated 0.5 or 1.5 seconds after RELAY 1 begins.

| TIME DELAY (sec) | DIP 1  | DIP 2  | DIP 3  |
|------------------|--------|--------|--------|
|                  | 1 sec. | 2 sec. | 4 sec. |
| 1                | ON     | OFF    | OFF    |
| 2                | OFF    | ON     | OFF    |
| 3                | ON     | ON     | OFF    |
| 4                | OFF    | OFF    | ON     |
| 5                | ON     | OFF    | ON     |
| 6                | OFF    | ON     | ON     |
| 7                | ON     | ON     | ON     |

### RELAY 2

The time delay on RELAY 2 is adjustable from 0 to 15 seconds by setting Dip Switches 4, 5, 6, & 7 according to the chart. The time delay set to RELAY 2 is the hold open time delay for the door. The Green LED will indicate that RELAY 2 is active and is sending a signal to the door control to hold the door open.

| TIME DELAY (sec) | DIP 4  | DIP 5  | DIP 6  | DIP 7  |
|------------------|--------|--------|--------|--------|
|                  | 1 sec. | 2 sec. | 4 sec. | 8 sec. |
| 1                | ON     | OFF    | OFF    | OFF    |
| 2                | OFF    | ON     | OFF    | OFF    |
| 3                | ON     | ON     | OFF    | OFF    |
| 4                | OFF    | OFF    | ON     | OFF    |
| 5                | ON     | OFF    | ON     | OFF    |
| 6                | OFF    | ON     | ON     | OFF    |
| 7                | ON     | ON     | ON     | OFF    |
| 8                | OFF    | OFF    | OFF    | ON     |
| 9                | ON     | OFF    | OFF    | ON     |
| 10               | OFF    | ON     | OFF    | ON     |
| 11               | ON     | ON     | OFF    | ON     |
| 12               | OFF    | OFF    | ON     | ON     |
| 13               | ON     | OFF    | ON     | ON     |
| 14               | OFF    | ON     | ON     | ON     |
| 15               | ON     | ON     | ON     | ON     |

### DELAY OPTION

The delay option allows the installer to choose the time delay between Relay 1 being activated and Relay 2 being activated. This time delay can either be set to 0.5 seconds or 1.5 seconds by changing the position of dipswitch 8.

| TIME DELAY (sec) | DIP 8 |
|------------------|-------|
| 0.5              | OFF   |
| 1.5              | ON    |

## 7 Troubleshooting

| PROBLEM                              | PROBABLE CAUSE                                                                                                                     | CORRECTIVE ACTION                                                                                                                                                                                                                                                                                                                                                                                                                                                                                                                                                                                  |
|--------------------------------------|------------------------------------------------------------------------------------------------------------------------------------|----------------------------------------------------------------------------------------------------------------------------------------------------------------------------------------------------------------------------------------------------------------------------------------------------------------------------------------------------------------------------------------------------------------------------------------------------------------------------------------------------------------------------------------------------------------------------------------------------|
| Time Delay Module will NOT activate. | <ol style="list-style-type: none"> <li>Faulty Power Supply.</li> <li>Activation input is faulty.</li> </ol>                        | <ol style="list-style-type: none"> <li>Insure correct power supply of 15 to 24 VAC / VDC. Power should come from an isolated transformer – not from the door control.</li> <li>Check for proper power at the orange and brown wires of the Time Delay Module. If power source is good, but not present at the connector, check the orange and brown wires for continuity with an ohm meter. Replace as necessary.</li> <li>When powering with DC power, observe polarity. Orange must be (-) and brown must be (+).</li> <li>Using a multi-meter, check both gray wires for continuity.</li> </ol> |
| Door stays open too long.            | <ol style="list-style-type: none"> <li>Total time delay between the Time Delay Module and the door control is too long.</li> </ol> | <ol style="list-style-type: none"> <li>For hold open time, use the MC-25 timer if the door control does not have a time delay adjustment. If it does, set the MC-25 to the minimum setting, and use the door control's hold time exclusively.</li> </ol>                                                                                                                                                                                                                                                                                                                                           |
| Door unlocks but will NOT open.      | <ol style="list-style-type: none"> <li>Lock device is drawing too much from the power supply.</li> </ol>                           | <ol style="list-style-type: none"> <li>Install a separate power supply for the lock device.</li> </ol>                                                                                                                                                                                                                                                                                                                                                                                                                                                                                             |

## 8 Company Contact

**LCN**<sup>®</sup>



Do not leave problems unresolved. If a satisfactory solution cannot be achieved after troubleshooting a problem, please contact LCN at 1-800-526-2400. If you must wait for the following workday to call LCN, leave the door inoperable until satisfactory repairs can be made. Never sacrifice the safe operation of the automatic door or gate for an incomplete solution.

For more information, visit [www.lcn.ingersollrand.com](http://www.lcn.ingersollrand.com).