

4820

NON-HANDED/NON-SIZED

AUTO-EQUALIZER[®]

LOW ENERGY DOOR OPERATOR

INSTALLATION AND ADJUSTMENT OF DOOR OPERATOR

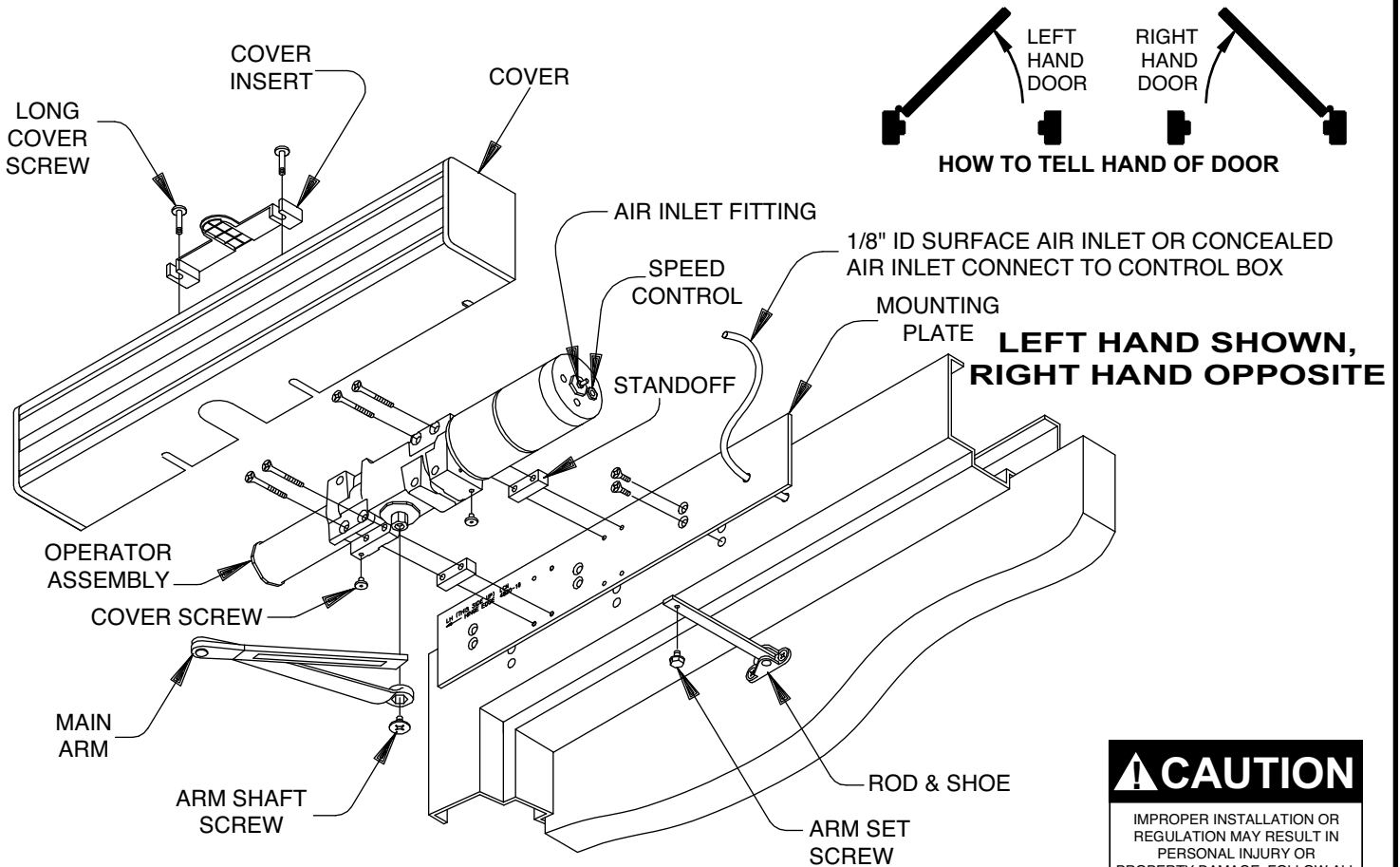

CAUTION
IMPROPER INSTALLATION OR REGULATION MAY RESULT IN PERSONAL INJURY OR PROPERTY DAMAGE. FOLLOW ALL INSTRUCTIONS CAREFULLY. FOR QUESTIONS, CALL LCN AT 800 - 526 - 2400

INSTALLATION

NOTE: This door operator requires additional system components, see LCN Closer Catalog.

1. Prepare frame per template (page 6), then secure mounting plate to frame with screws provided.
2. Secure operator assembly to mounting plate with 1/4 - 20 x 2 1/2 P.H.M.S.
3. Connect air line to air inler fitting.
4. Place main arm on operator shaft 100° to operator assembly and secure with shaft screw.
5. Attach rod and shoe to door.
6. Open door, insert rod in forearm tube, close door.
7. With rod and shoe at right angle to door, insert forearm set screw and tighten securely.

CLOSING FORCE ADJUSTMENT (See Fig. 1)

- To adjust CLOSING FORCE, use 5/32" allen wrench to turn the spring adjustment clockwise or counter-clockwise the required number of turns to match the door width in Tables 1 & 2. Maximum adjustment: 3 turns counter-clockwise and 10 turns clockwise.
- ADJUSTMENT FOR ADDITIONAL CLOSING FORCE AT LATCH. (See Fig. 2)
 - Remove forearm set screw and separate rod from tube.
 - Remove shoe screws and turn shoe over.
 - Reassemble arm, as in steps 6 & 7 of Installation.

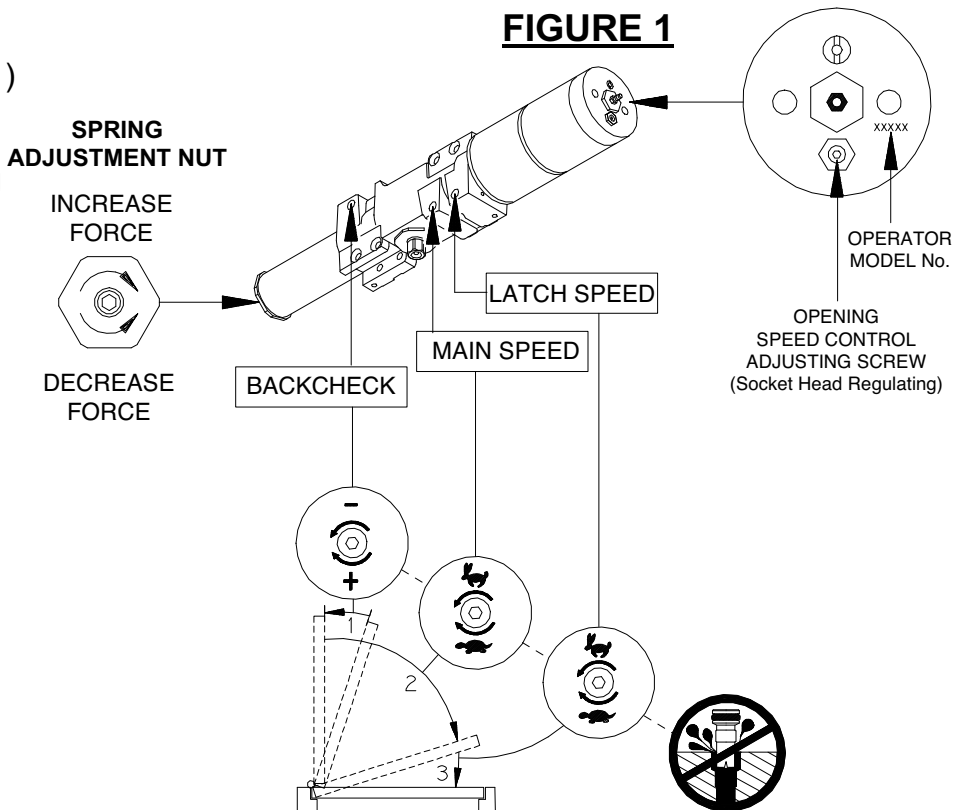

CLOSING SPEED ADJUSTMENT (See Fig. 1)

- A "normal" closing time from 90° open position is 5 to 7 seconds, evenly divided between main speed and latch speed
- Use 3/32" allen wrench provided.
- To slow MAIN SPEED of door, turn regulating screw (nearest to arm) clockwise.
- To slow LATCH SPEED of door, turn regulating screw (nearest to latch) clockwise.
- Do not allow door to slam into frame.

TABLE 1

EXTERIOR DOOR	
MAXIMUM DOOR WIDTH	NUMBER OF TURNS
30"	0 TURNS
36"	2 TURNS C.W.
42"	7 TURNS C.W.

TABLE 2

INTERIOR DOOR	
MAXIMUM DOOR WIDTH	NUMBER OF TURNS
34"	3 TURNS C.C.W.
38"	0 TURNS
48"	2 TURNS C.W.
54"	7 TURNS C.W.

FIGURE 2

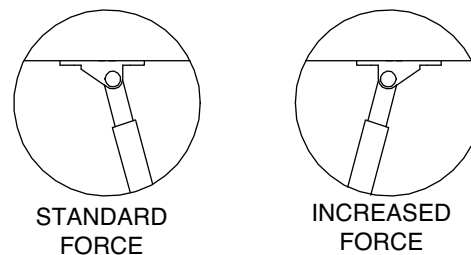

OPENING SPEED ADJUSTMENT

NOTE: FOR AIR PRESSURE REGULATION, SEE CONTROL BOX INSTRUCTIONS

- The door opening speed must be adjusted to suit the width and weight of door. The wider and/or heavier the door, the slower it should open. To determine opening speed, measure door leaf width and weight and set speed to open door from 0° to 80° for the time shown in Table 3 on page 3. The opening speed control adjusting screw is located in the end of the door operator near the tubing connection (see figure 1). Using a 3/32" allen wrench (provided), turn the speed control clockwise to slow the door, counter clockwise to increase speed.

TABLE 3

DOOR WEIGHT IN POUNDS	FASTEST OPENING TIME 0° to 80°		
	DOOR WIDTH IN INCHES		
	36"	42"	48"
100 lbs.	3.0 sec	3.5 sec	4.0 sec
125 lbs.	3.5 sec	4.0 sec	4.5 sec
150 lbs.	3.5 sec	4.0 sec	4.5 sec
200 lbs.	4.0 sec	4.5 sec	5.5 sec

NOTE:

If door width or weight is between the sizes and pounds listed, use the time shown for the next wider or heavier door.



- If door weight cannot be measured, the weight can be estimated by finding the area of the door (length x width) and multiplying it by the weight per square feet for the door type that is being used as shown in Table 4 below.

TABLE 4

TYPE OF DOOR	WEIGHT PER SQ. FT.
- Solid Core Wood - 20 Ga. Flush Hollow Metal - Aluminum x 1/4" Glass	5.5 lbs
- Mineral Core Door - 16 Ga. Flush Hollow Metal - Aluminum x 1" Glass	7.0 lbs

NOTE:

These weights are for 1 3/4" thick doors. If the doors are thicker or thinner, consult door manufacture for proper weight or weigh the door.

BACKCHECK ADJUSTMENT

- Backcheck slows the door swing as it approached full opening (see figure 1 on page 2).
- Increase the resistance of backcheck only if necessary to prevent the door from striking a wall. To do this, turn the regulating screw (nearest to hinge) clockwise by quarter turns. **DO NOT USE AN ABRUPT BACKCHECK.**

DELAY TIME ADJUSTMENT

After opening, the door should remain at the 90° position for no less than 5 seconds. This "Delay Time" can be increased to approximately 30 seconds by turning the timer adjustment wheel(s) clockwise. For the location of this wheel(s), refer to 7900 or 7980 Series Control Box Instruction Sheet. Adjust "Delay Time" to maximum practical for the elderly or handicap. Time cycle begins when switch or scanner is released.

ATTACH COVER

- Slide cover insert into the top cutout in cover (see figure 4).
- Push cover over the operator assembly and against mounting plate.
- Insert cover screws and tighten securely.

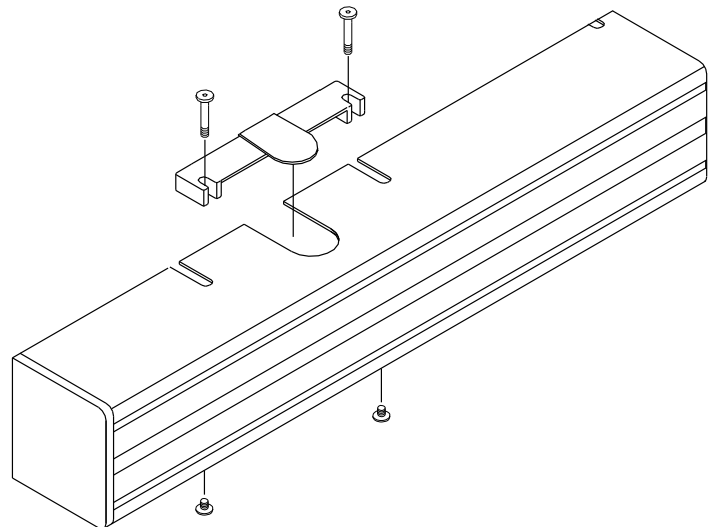

LOCATING THE CAUTION/ AUTOMATIC DOOR DECAL

1. Local one decal on each side of the door near lock stile of door, approximately 18" min. to 42" max. above the floor. The decal location must be visible without interference from door trim, panic devices, etc.
2. Clean area 6" x 6" where decals will be placed.
3. Apply one decal (item 17 on page 5) on each side of door. Remove backing and "roll" onto door to avoid trapping air under decal.



DOUBLE LEVER ARM SET SCREW ADJUSTMENT

1. It may be necessary to adjust the fully open door position. Minor adjustment can be obtained by using the telescoping arm as follows (see figure 5):
 - A. Shorten length of arm to decrease door opening.
Lengthen arm to increase door opening.
 - B. Loosen arm set screw and adjust arm to preferred length.
 - C. Tighten arm set screw securely after adjustment.
 - D. After arm adjustment is made, cycle door to insure that it is operating properly.

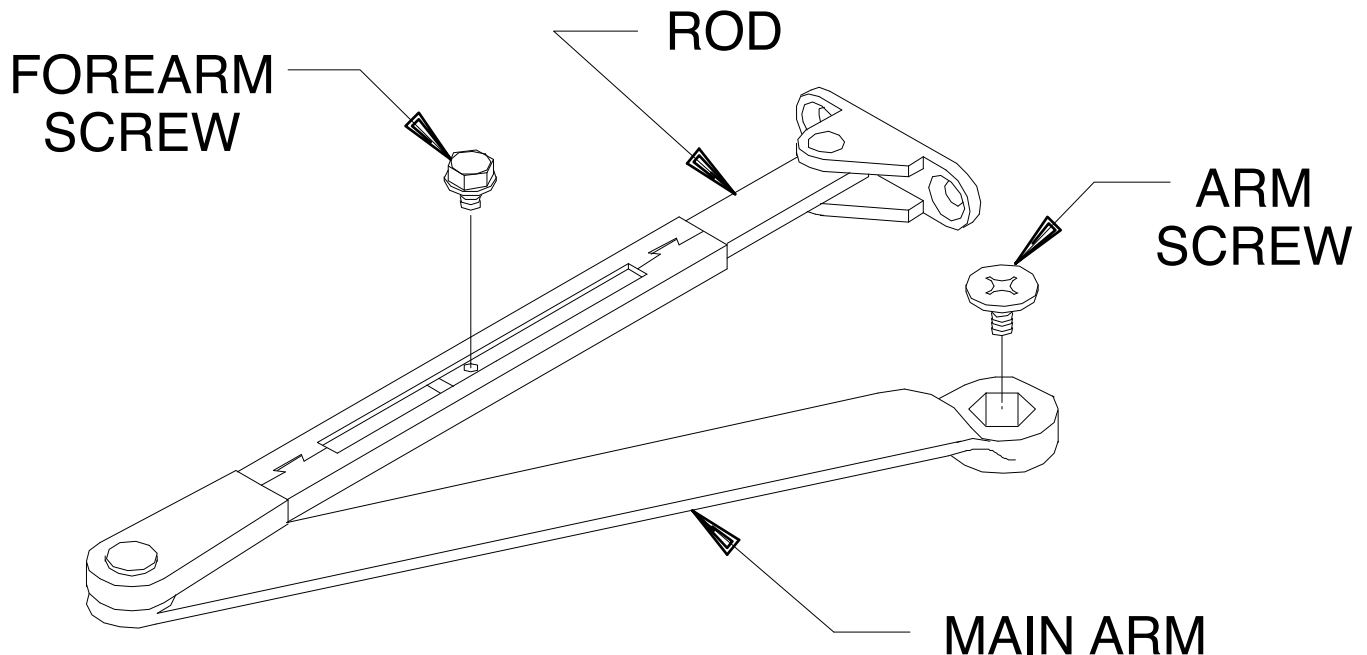

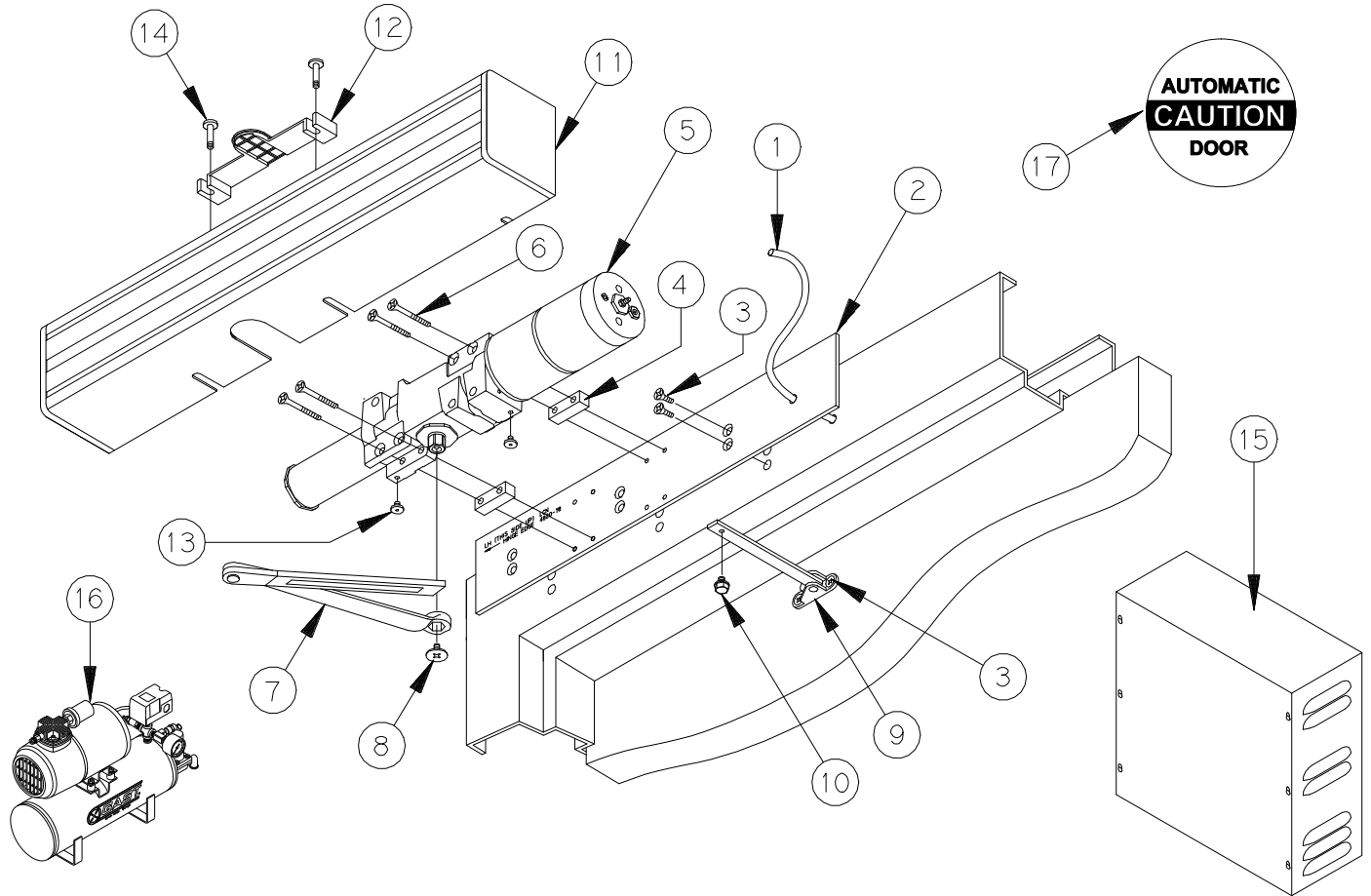

ITEM No.	PART No.	DESCRIPTION	QUANTITY
1	925	1/8 " I.D. Pneumatic Tubing	Order Length Required
2	4810-18 4820-18G	Standard Mounting Plate Flush Ceiling Mounting Plate	1
3	No.14 x 1 1/2" 1/4-20 x 5/8"	Phillips Head Wood Screw or Phillips Head Machine Screw	8
4	4820-182	Standoff	2
5	4820-3071	LCN Switch-Actuated Auto Equalizer®	1
6	1/4-20 x 2 1/2"	Phillips Head Machine Screw	4
7	4820-77	Main Arm & Forearm	1
8	4020-159	Arm Screw	1
9	4820-79	Rod & Shoe	1
10	4820-83	Arm Set Screw	1
11	4820-72	Cover	1
12	4820-163	Cover Insert	1
13	4820-31	Cover Screw	2
14	4820-31L	Long Cover Screw	2
15	900 or 7980 Series	Control Box	1
16	920 or 921	Compressor (optional)	1
17	4820-155G	Decal	2

OVER DOOR ON 18 APPLIES TO:

4822 } 100° OPENING MAX.
 4822 } 90° POWER OPENING

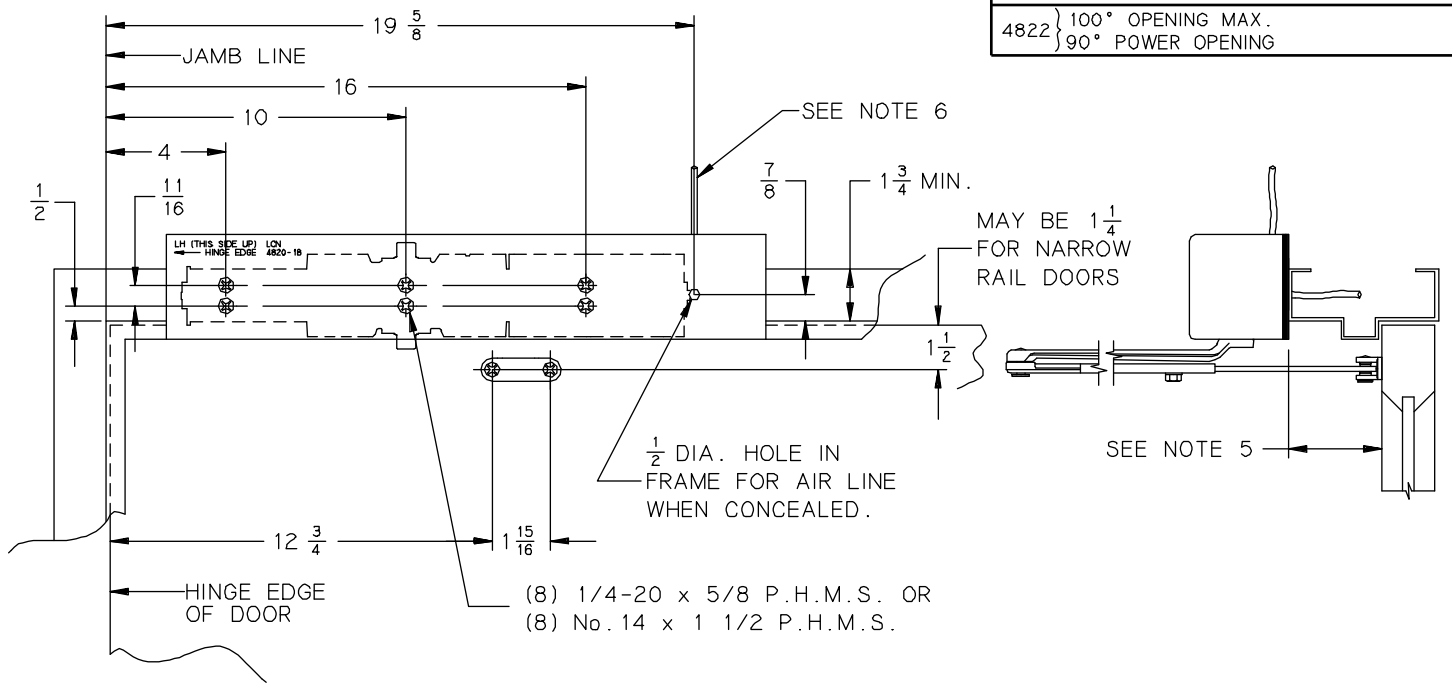

LEFT HAND SHOWN, RIGHT HAND OPPOSITE

OVER DOOR ON 18G APPLIES TO:

4822 } 100° OPENING MAX.
 4822 } 90° POWER OPENING

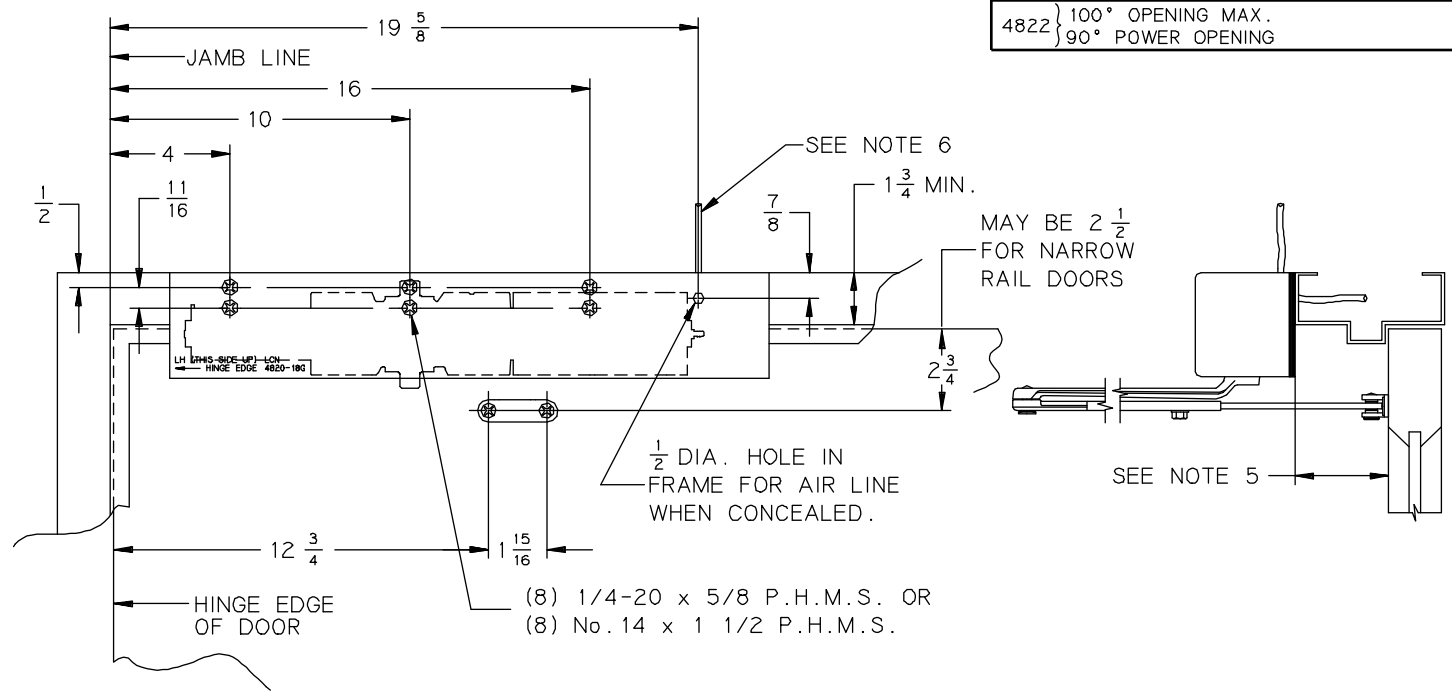

LEFT HAND SHOWN, RIGHT HAND OPPOSITE

GENERAL NOTES-

1. MOUNT PROPER SIDE OF MOUNTING PLATE PER HAND OF DOOR.
2. MOUNTING SCREWS No. 14 W.S. OR 1/4 - 20 M.S
3. CLOSER SIZE 20 x 3 1/2 x 3 5/16
4. LOCATE OPERATOR & SHOE FROM C OF PIVOTS OR SWING CLEAR HINGE WHEN USED.
5. STANDARD ARM ACCOMMODATES REVEALS UP TO 4 1/2". REVEALS FROM 4 1/2" TO 8" USE OPTIONAL LONG ROD & SHOE.
6. 1/8" I.D. TUBING CONNECTED TO CONTROL BOX.
7. MAXIMUM BUTT SIZE 5"x 5"

INCH	1/2	11/16	7/8	1 1/4	1 1/2	1 3/4	1 15/16	2 1/2
M M	13	18	22	32	38	44	49	64

INCH	2 3/4	3 5/16	3 1/2	4	10	12 3/4	16	19 5/8	20
M.M.	70	84	89	102	254	324	406	498	508

No.	REVISION	BY	DATE
2	TEMPLATE UPDATE	JEJ	6/96



APP BY JEJ 6/96
DO NOT SCALE

PUSH SIDE/TOP JAMB MOUNTED NON-HANDED AUTO-EQUALIZER® ON 18 OR 18G PLATE

4820