

**DOOR CLOSER WITH ELECTRONIC RELEASE & MULTI - POINT HOLD OPEN.
(COMPANION UNIT TO THE 4410 MED SERIES DETECTOR UNIT)**

INSTALLATION INSTRUCTIONS

1. Closer is handed at factory and marked with an "R" or "L" on top of packing nut. The hand of closer must match hand of door (See door handing diagram at bottom of page). Determine closer mounting template to be used - Standard or Flush-Ceiling (see Pg.4). **MEC mounting should match corresponding MED mounting.** Refer to proper template for entire installation.
2. Voltage supplied to door frame **MUST** be 24V. **Refer to selected MED wiring diagram for electrical connection information.**
3. Before beginning Step 3, determine which type of wiring option is to be used and follow the corresponding instructions.

FOR CONCEALED WIRING: See Fig. 3 on page 3.

- A. Prepare frame per proper template on page 4. Be sure all the holes are dimensioned correctly before drilling and tapping.
- B. Assemble conduit connector provided to flexible conduit, then attach to hole in mounting plate.
- C. Secure mounting plate to frame with screws provided.

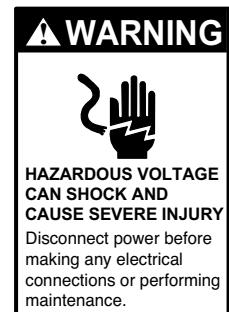

FOR SURFACE WIRING: See Fig. 4 on page 3. **NOTE:** Remove knockout in top of cover.

- A. Prepare frame per proper template on page 4. Be sure all holes are dimensioned correctly before drilling and tapping.
 - B. Secure mounting plate to frame with screws provided.
 - C. Attach the surface run 1/2" EMT conduit to hole in bracket on mounting plate. Be sure conduit is securely attached to bracket.
4. Make wiring connections at this time. Connect two black wires to 2 solenoid leads on MED unit REF: White - Black / White - Red (**MED & MEC must have same power input**). Green wire **MUST** be connected to an earth ground. (See Fig. 3 & 4 on page 3)
 5. Place main arm onto shaft, 90° to closer body and secure with arm shaft screw.
 6. Attach rod & shoe to door (per proper template on page 4) with screws provided.
 7. Open door part way and insert rod into forearm, then close door. With **main arm** at right angle (90°) to door, insert arm set screw and tighten securely.
 8. Regulate closer and perform electrical checkout as instructed on page 2 before installing closer cover.

HOW TO TELL HAND OF DOOR:

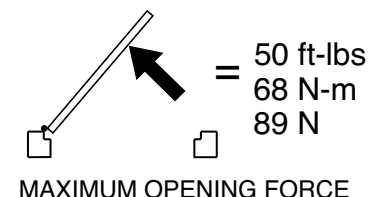
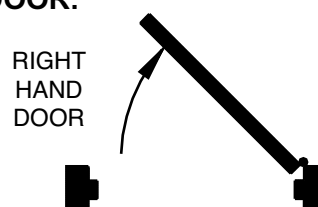
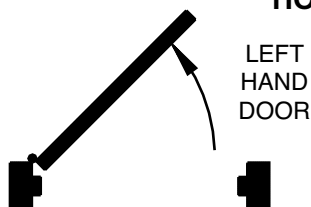

REGULATION INSTRUCTIONS

SEE FIGURE 2 ON OPPOSITE PAGE FOR REGULATING SCREW LOCATION, DOOR CONTROL DIAGRAM & SPRING POWER ADJUSTMENT

- 1. SPRING POWER ADJUSTMENT:** Do not allow door to slam into frame. Spring power should be adjusted **only** if more power is needed to close the door. Turning spring adjustment clockwise will increase spring power. 6 turns maximum adjustment.
- 2. Regulation:** A "normal" closing time from a 90° position is 5 to 7 seconds, equally divided between **MAIN** and **LATCH SPEED**. If adjustments are needed, use the socket screw key provided. To adjust **MAIN SPEED**, turn regulating screw clockwise to slow door speed or c.c.w. to increase speed. **LATCH SPEED** is adjusted in the same way. When adjusting the **BACK CHECK**, use the least amount of force necessary to sufficiently retard the swing of door. To adjust closer **BACKCHECK**, turn regulating screw clockwise to increase amount of force or c.c.w. to reduce the amount of force. **DO NOT USE ABRUPT BACKCHECK SETTING OR EXPECT CLOSER TO ACT AS A STOP !**



ELECTRICAL CHECKOUT

AFTER COMPLETION OF INSTALLATION & WIRING, AND WITH THE UNIT PROPERLY POWERED, PERFORM THE FOLLOWING TESTS:

1. With power on, open the door any position. Door should remain in that position, unless closer hold open is designed to bypass a portion of the door swing (look for label on cylinder). For a bypass model to hold open, the door must be opened beyond degree of door swing indicated on label.
2. If door does not hold open, push on / off switch. If door still does not hold open, verify proper voltage input at solenoid leads.
3. Turn power off. Door should close completely.
4. To release manually, pull on door firmly. Door should close completely.
5. System should be checked at regular intervals. It is recommended that steps 1-3 be repeated every 90 days.

ELECTRICAL DATA FOR DOOR HOLDER SOLENOID:

24V AC-DC Nominal +10% - 15% @ .090 Amp. Max.

HOLD OPEN FORCE ADJUSTMENT

IF DOOR IS HARD TO PULL OUT OF HOLD OPEN, ADJUST AS SHOWN

IMPORTANT

Closer leaves the factory set at maximum holding force. The holding force may be decreased and increased again, but it cannot be increased beyond the original setting.

TURN CLOCKWISE
TO DECREASE
HOLDING FORCE

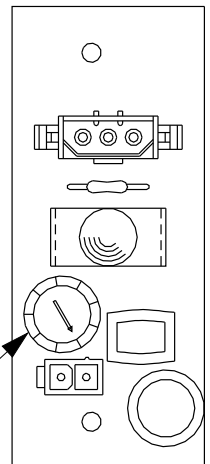

Figure 1

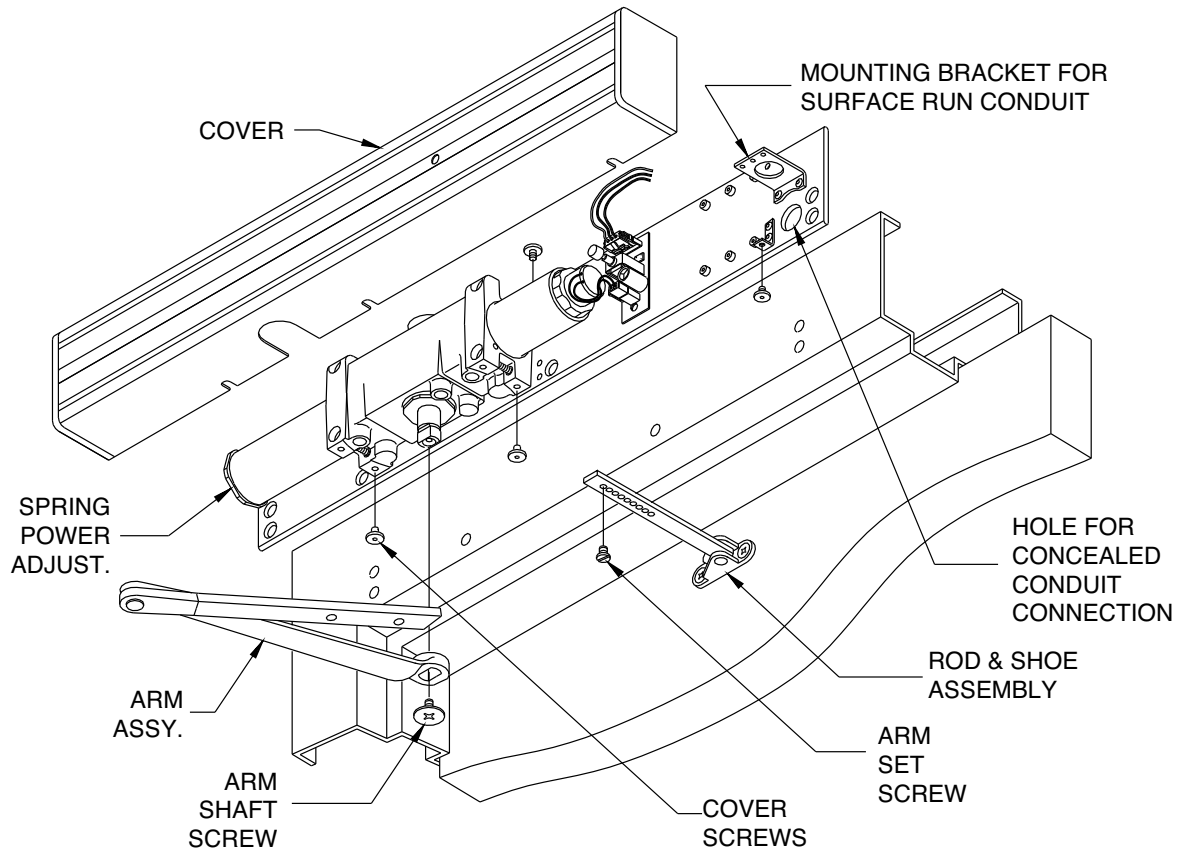

Figure 2

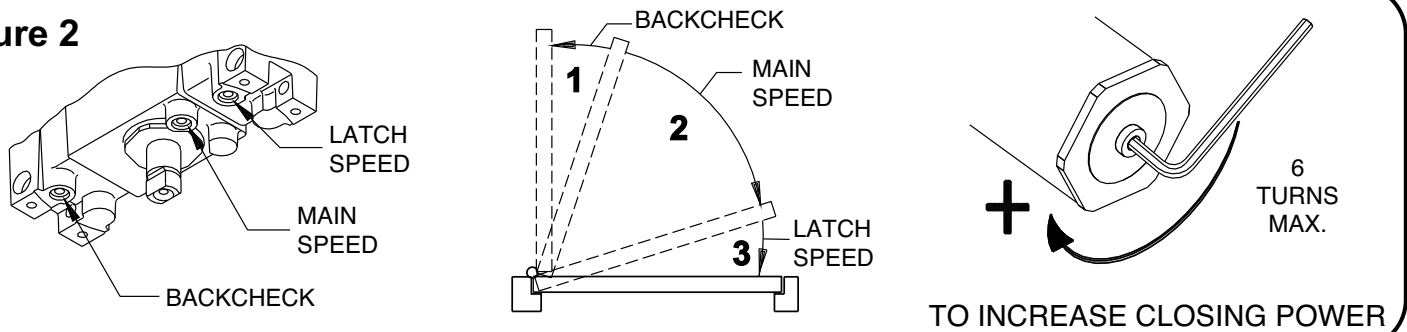

Figure 3

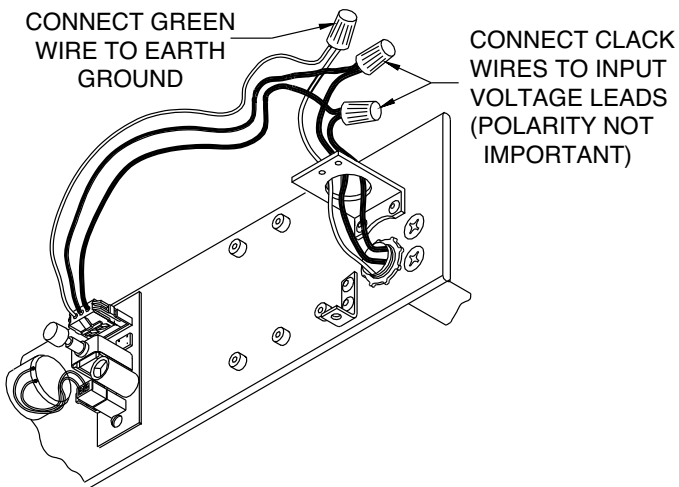
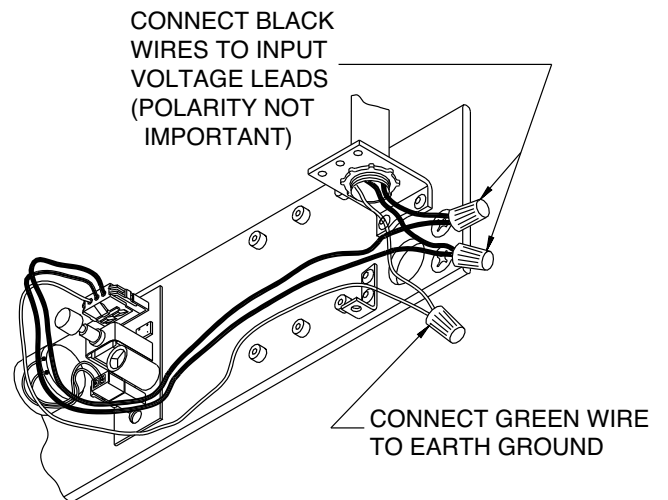

Figure 4



WARNING



**HAZARDOUS VOLTAGE
CAN SHOCK AND
CAUSE SEVERE INJURY**
Disconnect power before
making any electrical
connections or performing
maintenance.

4413 MEC } HOLD OPEN ANY POINT TO 160°
4414 MEC } HOLD OPEN BYPASS 80° OR 140°
4413 MECL } HOLD OPEN ANY POINT TO 170°
4414 MECL } HOLD OPEN BYPASS 80° OR 140°

LEFT HAND DOOR AND CLOSER
SHOWN, RIGHT HAND OPPOSITE

1/97

"L" INDICATES LONG ARM

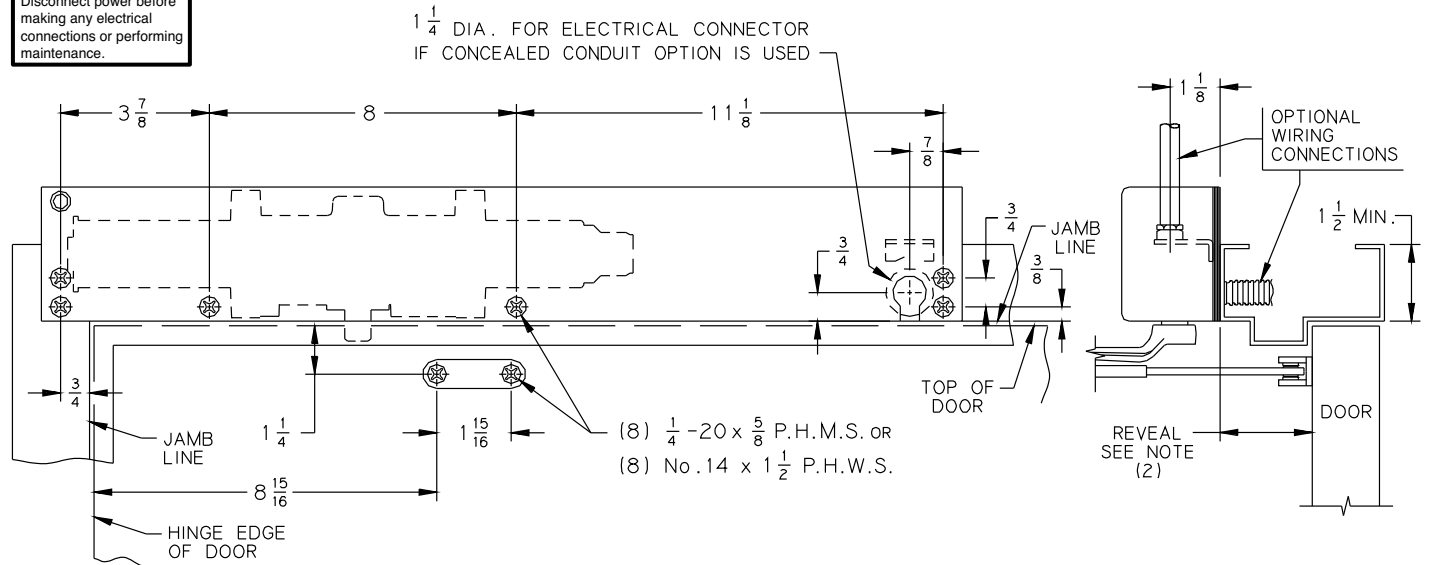

4413G MEC } HOLD OPEN ANY POINT TO 160°
4414G MEC } HOLD OPEN BYPASS 80° OR 140°
4413G MECL } HOLD OPEN ANY POINT TO 170°
4414G MECL } HOLD OPEN BYPASS 80° OR 140°

"L" INDICATES LONG ARM

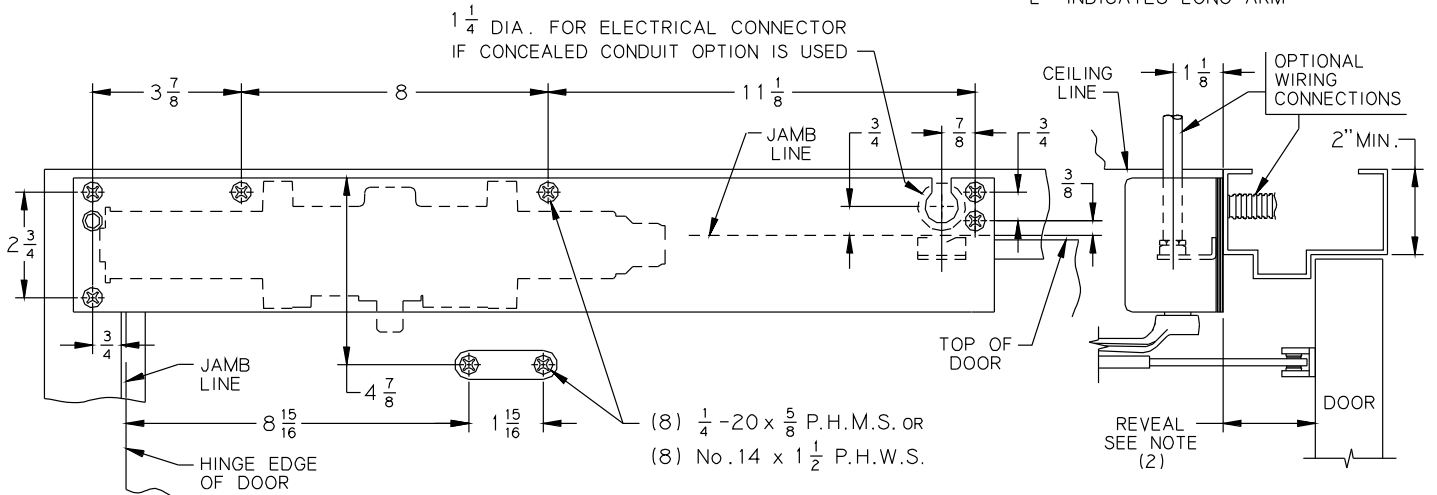

NOTES-

1. VOLTAGE SUPPLIED TO UNIT MUST BE 24 VOLTS.
2. LONG ARMS REQUIRED FOR OPENING BEYOND 160°. REVEAL NOT TO EXCEED 3 7/8. (5 3/4 FRAME).
3. MAXIMUM STOP THICKNESS 5/8.
4. ELECTRICAL CONNECTOR IS PROVIDED BY LCN.
5. IF DOOR IS HUNG ON PIVOTS, LOCATE CLOSER AND SHOE FROM CENTERLINE OF PIVOT. IF DOOR IS HUNG ON SWING CLEAR HINGES, CONSULT FACTORY.
6. FLOOR OR WALL STOPS SHOULD BE USED.
7. FOR ADDITIONAL INFORMATION ON RECOMMENDED USE OF THIS UNIT CONSULT NFPA-72E PAMPHLET.
8. REINFORCING PER ANSI/SDI-100 RECOMMENDED FOR HOLLOW METAL DOORS AND FRAMES.

TABLE OF SIZES

MAXIMUM DOOR WIDTH INTERIOR DOORS ONLY	CLOSER No.
2'4" THRU 3'0"	4413 MEC
3'1" THRU 4'0"	4414 MEC

INCH	1/4	3/8	1/2	5/8	3/4	7/8	1 1/8	1 1/4	1 1/2	1 15/16	2
M.M.	6	10	13	16	19	22	29	32	38	49	51
INCH	2 9/16	2 3/4	3 7/8	5 3/4	8	8 15/16	11 1/8	2'4"	3'0"	3'1"	4'0"
M.M.	65	70	98	146	203	227	283	700	900	925	1200

No.	REVISION	BY	DATE
3	CAD CONVERSION	DRM	05/94



APP BY DRM 5/94
DO NOT SCALE

PUSH SIDE, TOP JAMB MOUNTED
CLOSER WITH MULTI-POINT HOLD OPEN

4410 MEC