

# 4010T DE INSTRUCTION SHEET

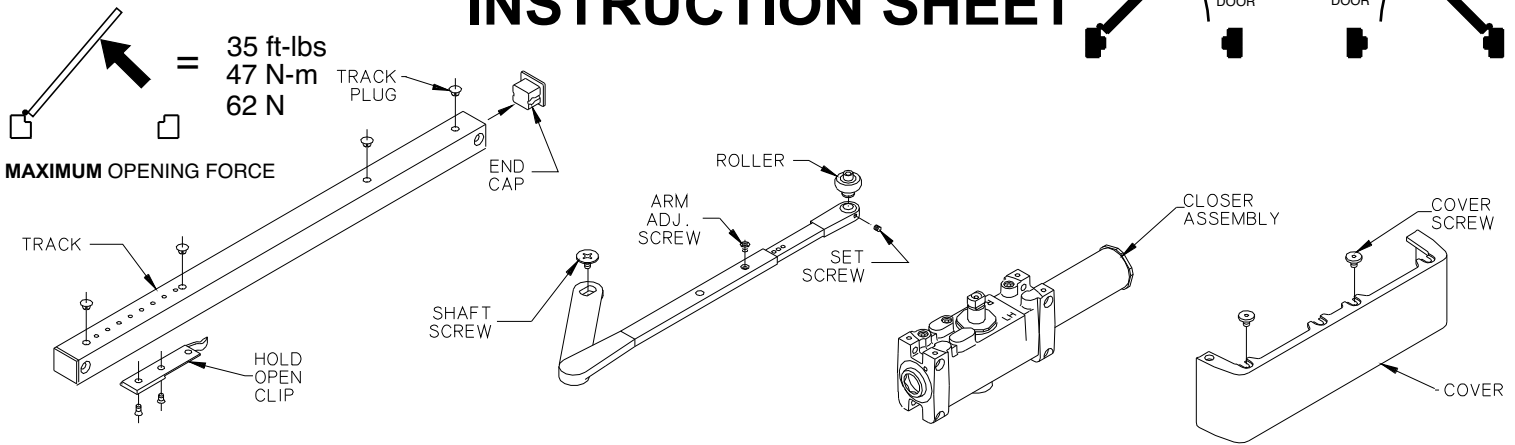
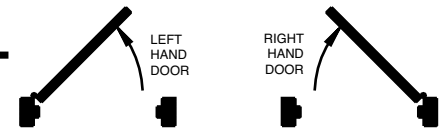

## INSTALLATION:

1. Closer is handed at factory and must match hand of door. Hand of closer appears in line with three regulating screws.
2. Prepare door & frame per proper template. Using fasteners provided, mount closer on door to proper dimensions.
3. Place arm on closer shaft & secure with shaft screw.
4. Remove end cap from track. Insert roller into track and replace end cap. Put track hole plugs into holes on top of track. Using fasteners provided, mount track on frame.
5. Loosen set screw in end of arm; open door to approximately 30° and pull arm over top of door. Connect arm to track roller and tighten set screw firmly.
6. Open door slightly and place cover on closer. Hold cover firmly against door while tightening cover screws securely with socket screw key (included).

## REGULATION:

Door closer regulation is preset at the factory. Adjust as follows only if necessary: A "normal" closing time from a 90° open position is 5 to 7 seconds, evenly divided between main speed & latch speed (see figure below). Use socket screw key furnished to adjust regulating screws. To slow main speed of door, turn regulating screw closest to shaft clockwise. To slow latch speed, turn regulating screw closest to hinge clockwise.

## BACKCHECK:

To increase backcheck intensity, turn regulating screw closest to the latch clockwise. **DO NOT USE ABRUPT BACKCHECK. DO NOT USE DOOR CLOSER AS A DOOR STOP.**

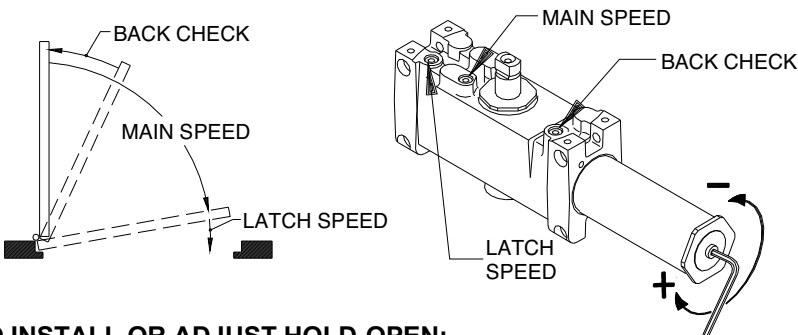

## SPRING ADJUSTMENT

INCREASE

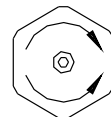

DECREASE

CAUTION

IMPROPER INSTALLATION OR REGULATION MAY RESULT IN PERSONAL INJURY OR PROPERTY DAMAGE. FOLLOW ALL INSTRUCTIONS CAREFULLY. FOR QUESTIONS, CALL LCN AT 800 - 526 - 2400

## TO INSTALL OR ADJUST HOLD-OPEN:

Hold-open track and spring clip assembly are non-handed. Illustration at right shows assembly in track. For 3/16" -- 3 5/16" reveals, hold-open is available from 80° - 100° by adjusting arm length and/or location of clip assembly in track. Tip spring clip into track. Locate to desired position, and install screw (3) securely. Tip cam (2) into track. Locate as show. Install long (green) screw (1) securely. Push door into hold-open position. For MORE HOLDING POWER - loosen the long (green) screw (1), slide cam (2) toward LATCH; re-tighten long (green) screw (1) securely. For LESS HOLDING POWER - loosen long (green) screw (1), slide cam (2) toward HINGE edge of door; re-tighten long (green) screw (1) securely.

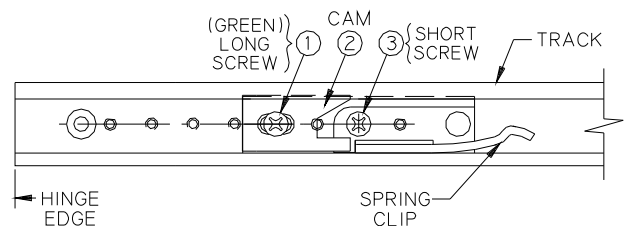

HINGE FACE MTG APPLIES TO

4013T DE  
4014T DE UP TO 100°

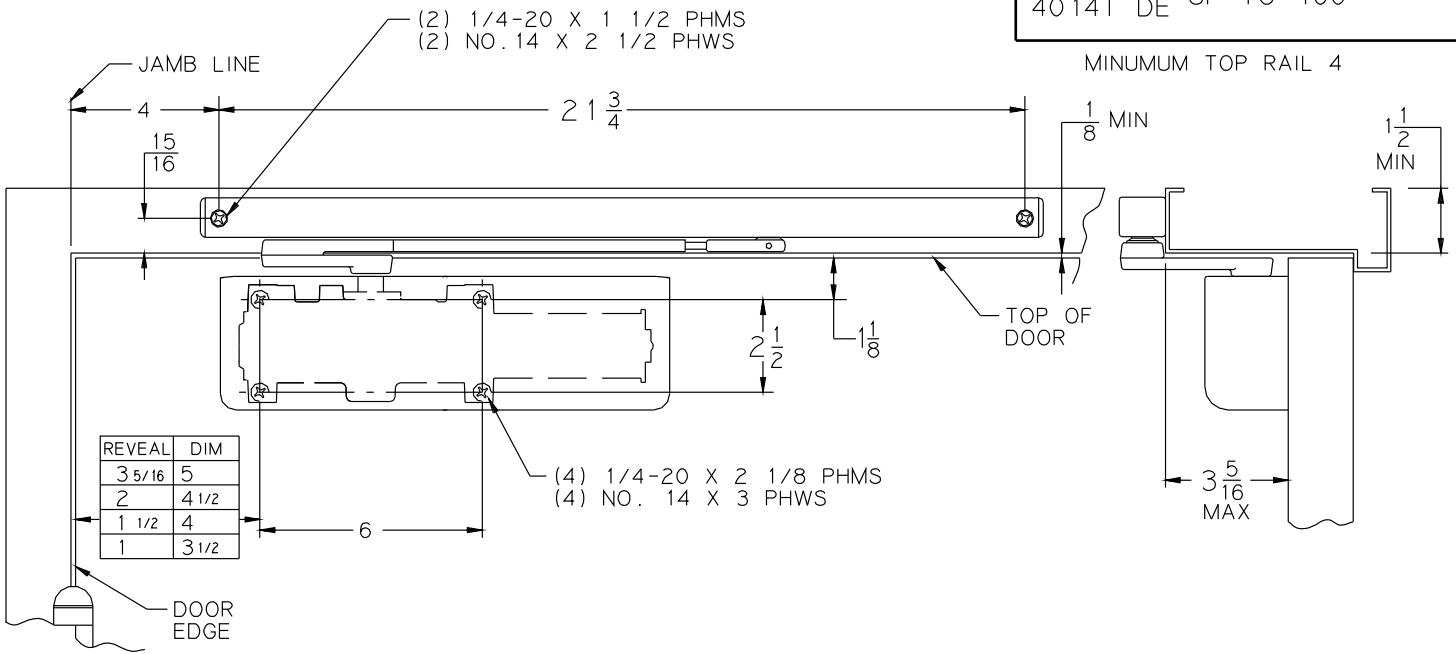

HINGE FACE ON 18 APPLIES TO

4013T DE  
4014T DE UP TO 100°

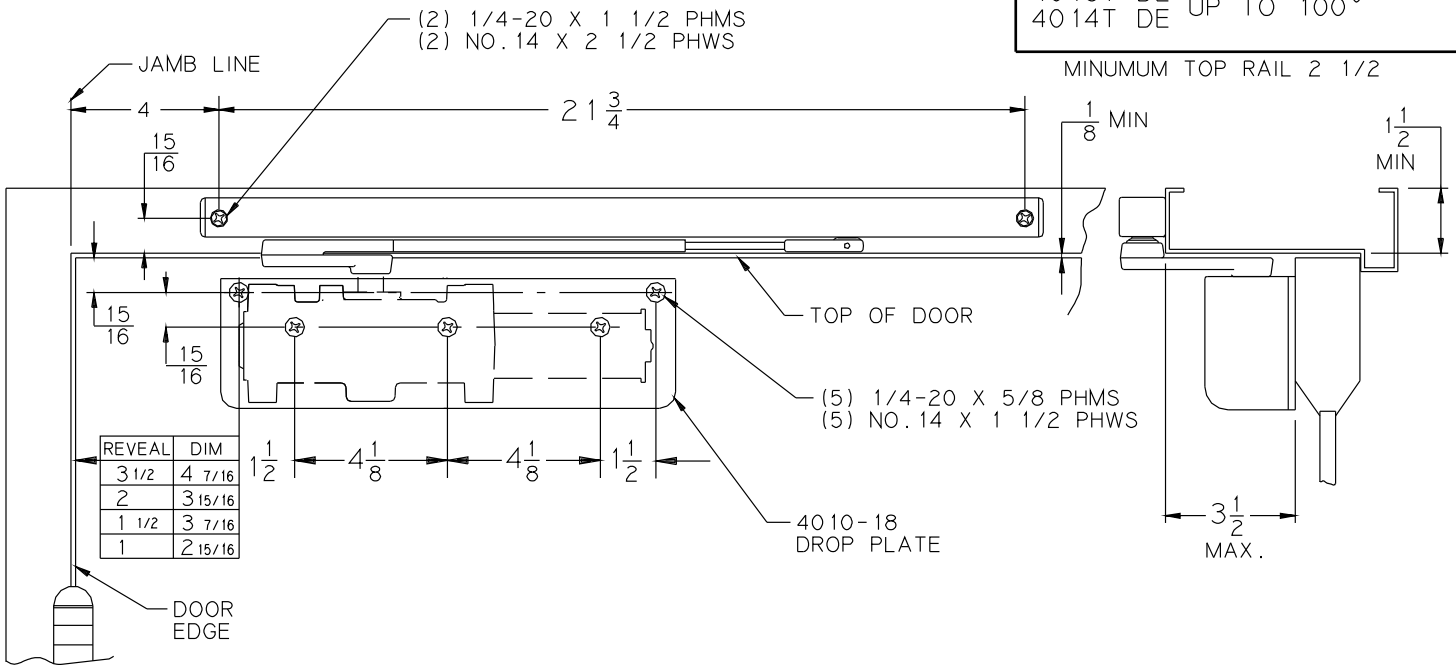

INCH	1/4	9/16	5/8	3/4	7/8	15/16	1 1/2	1 3/4	2	2 1/8	2 5/32	2 1/4	2 3/8	2 1/2	3	3 1/2	4	4 1/8	4 7/16	5	6	12 1/4	21 3/4
M.M.	6.4	14.3	15.9	19.1	22.2	23.8	38.1	44.5	50.8	54.0	54.8	57.2	60.3	63.5	76.2	88.9	101.6	104.8	112.7	127	152.4	311.2	552.5

NOTES:

- 1 - RIGHT HAND DOOR AND CLOSER SHOWN - LEFT HAND OPPOSITE.
- 2 - CLOSER SIZE 12 1/4" X 3 1/2" X 2 5/32" (2 3/8" WITH DROP PLATE 4010-18)
- 3 - LOCATE CLOSER AND TRACK FROM CL OF PIVOT OR SWING CLEAR HINGE WHEN USED.
- 4 - FOR 8 3/4" OR LESS DOUBLE EGRESS FRAMES, REVEAL NOT TO EXCEED 3 5/16" ( 3 1/2" WITH PLATE )
- 5 - REINFORCING PER ANSI/SDI 100 RECOMMENDED FOR HOLLOW METAL DOORS AND FRAMES.

AUXILIARY STOP RECOMMENDED

DO NOT SCALE			
NO	REVISIONS	BY	DATE



SMOOTHEE CLOSER WITH TRACK AND DOUBLE EGRESS ARM. HINGE FACE MOUNTED ON DOOR OR DROP PLATE

BY 2-19-93 LLZ<sup>NO.</sup>

APPR. 2-19-93 GSN

4010T-DE

5/8 STEP DOWN FRAME

HINGE FACE MTG APPLIES TO

4013T DE  
4014T DE UP TO 100°

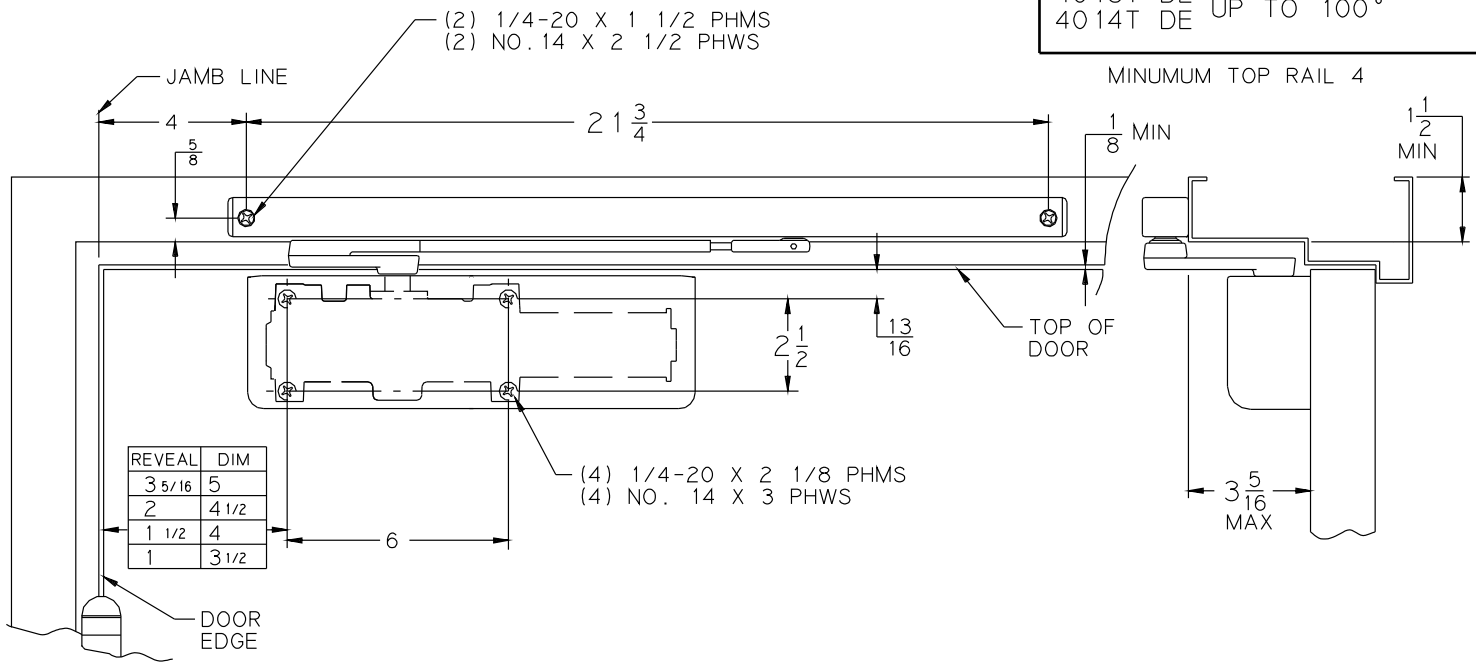

5/8 STEP DOWN FRAME

HINGE FACE ON 18 APPLIES TO

4013T DE  
4014T DE UP TO 100°

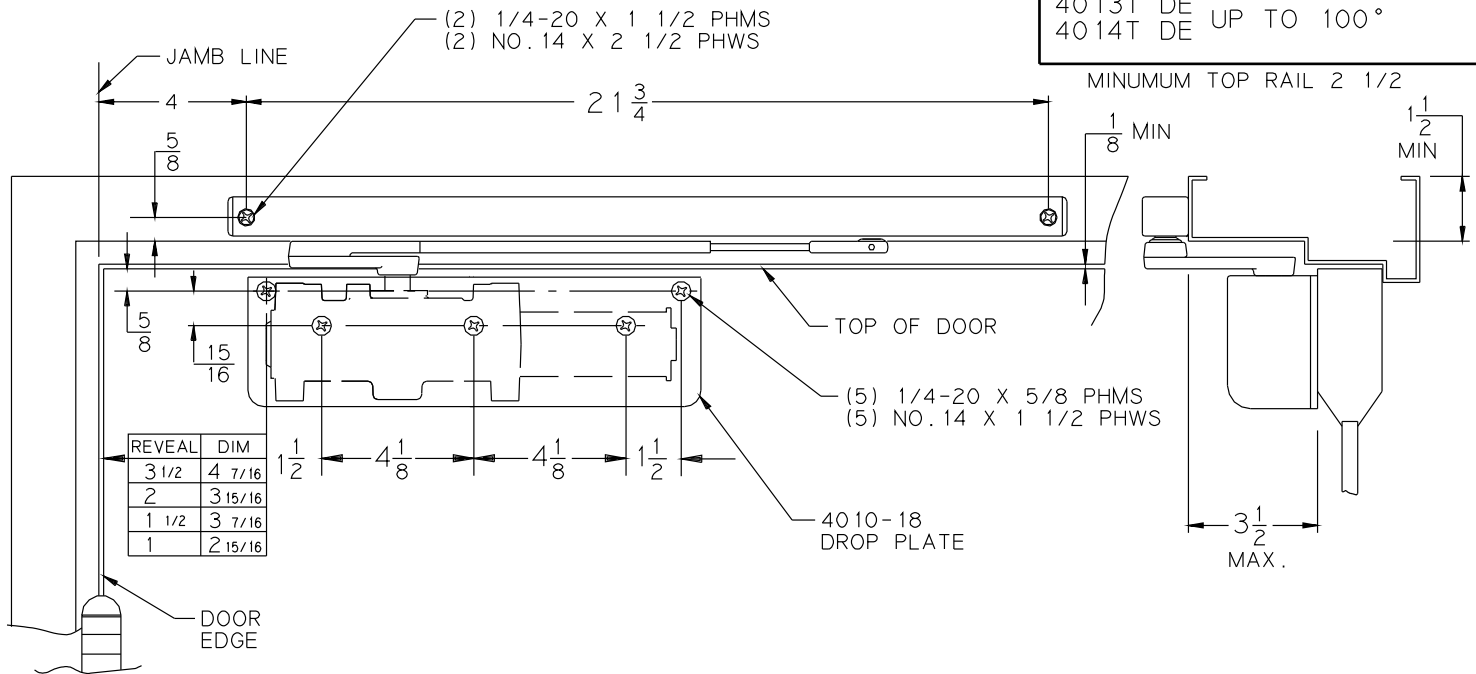

INCH	1/4	9/16	5/8	3/4	7/8	15/16	1 1/2	1 3/4	2	2 1/8	2 5/32	2 1/4	2 3/8	2 1/2	3	3 1/2	4	4 1/8	4 7/16	5	6	12 1/4	21 3/4
M.M.	6.4	14.3	15.9	19.1	22.2	23.8	38.1	44.5	50.8	54.0	54.8	57.2	60.3	63.5	76.2	88.9	101.6	104.8	112.7	127	152.4	311.2	552.5

NOTES:

- 1 - RIGHT HAND DOOR AND CLOSER SHOWN - LEFT HAND OPPOSITE.
- 2 - CLOSER SIZE 12 1/4" X 3 1/2" X 2 5/32" (2 3/8" WITH DROP PLATE 4010-18)
- 3 - LOCATE CLOSER AND TRACK FROM CL OF PIVOT OR SWING CLEAR HINGE WHEN USED.
- 4 - FOR 8 3/4" OR LESS DOUBLE EGRESS FRAMES, REVEAL NOT TO EXCEED 3 5/16" ( 3 1/2" WITH PLATE ).
- 5 - REINFORCING PER ANSI/SDI 100 RECOMMENDED FOR HOLLOW METAL DOORS AND FRAMES.

AUXILIARY STOP RECOMMENDED

DO NOT SCALE				
NO.	REVISIONS	BY	DATE	
				SMOOTHEE CLOSER WITH TRACK AND DOUBLE EGRESS ARM. HINGE FACE MOUNTED ON DOOR OR DROP PLATE
				BY 2-19-93 LLZ
				APPR. 2-19-93 GSN
				NO. 4010T-DE