

4003T / 4004T INSTALLATION & INSTRUCTION

CAUTION
IMPROPER INSTALLATION OR REGULATION MAY RESULT IN PERSONAL INJURY OR PROPERTY DAMAGE. FOLLOW ALL INSTRUCTIONS CAREFULLY. FOR QUESTIONS, CALL LCN AT 800 - 526 - 2400

1. The 4000T Model is for a 90° Pocket Installation only. Determine required template for your installation, (see following pages) and mount closer on wall to dimensions shown. Secure with screws provided.
2. Remove end cap from track, and insert track roller. Replace end cap, then mount track on door to dimensions shown. Secure with screws provided. Place track plugs in holes on top of track.
3. Loosen set screw in arm. Connect arm to track roller, and tighten set screw firmly.
4. Place arm spacer over top shaft to closer. **DOOR MUST REMAIN IN CLOSED POSITION FOR FOLLOWING ASSEMBLY STEPS.**
5. Swing arm toward closer and rest the hub of the arm on top of the closer shaft.
6. Place a wrench on the bottom shaft of the closer, and rotate away from the hinge (approx. 30°). When the flats in the arm line up with first available flats of the shaft, slide the arm hub over the shaft. Insert the shaft screw and tighten securely.

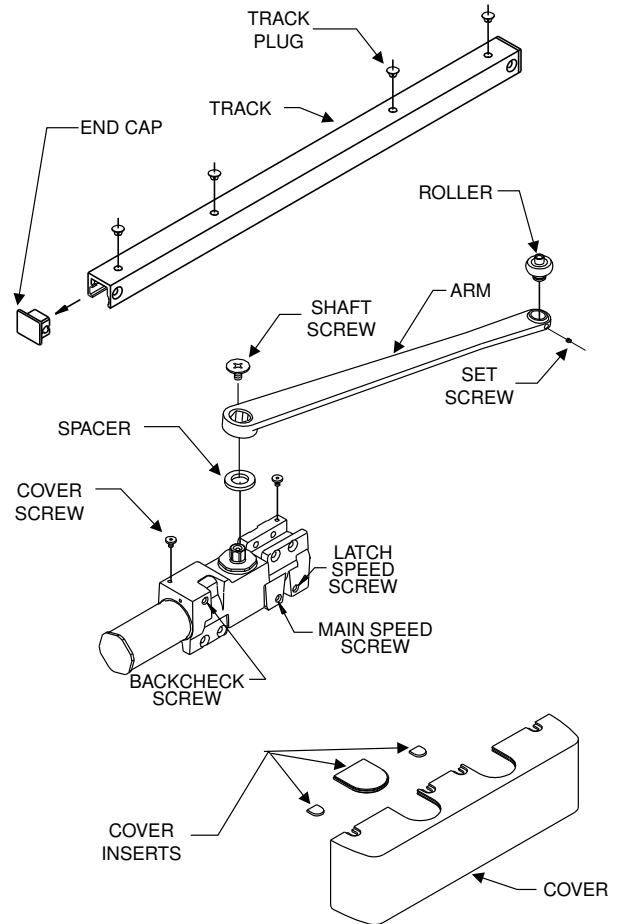

REGULATION:

Do not allow door to slam into frame. A "normal" closing time from a 90° position is 5 to 7 seconds, equally divided between **MAIN SPEED** and **LATCH SPEED**. If adjustments are needed, use 3/32" allen wrench provided. To adjust **MAIN SPEED**, turn regulating screw clockwise to slow door speed or c.c.w. increase speed. **LATCH SPEED** is adjusted in the same way. When adjusting the **BACKCHECK**, turn regulating screw clockwise to increase amount of force or c.c.w. to reduce the amount of force. **DO NOT USE ABRUPT BACKCHECK SETTING OR EXCEPT CLOSER TO ACT AS A STOP !**

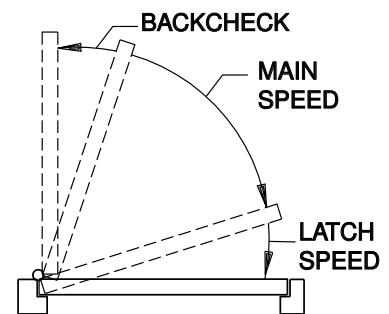

ATTACH COVER

First place inserts in proper cutouts, push cover against door frame and tighten both cover screws securely.

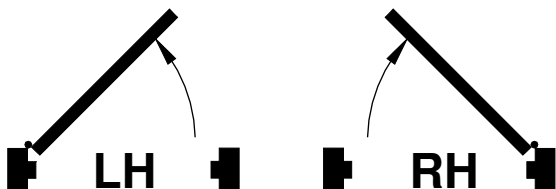

WARNING
DO NOT REMOVE SPRING TUBE FROM THIS PRODUCT
EXTREMELY STRONG SPRINGS INSIDE
IF REPAIRS AS NECESSARY RETURN TO FACTORY.

POCKET PIVOTS

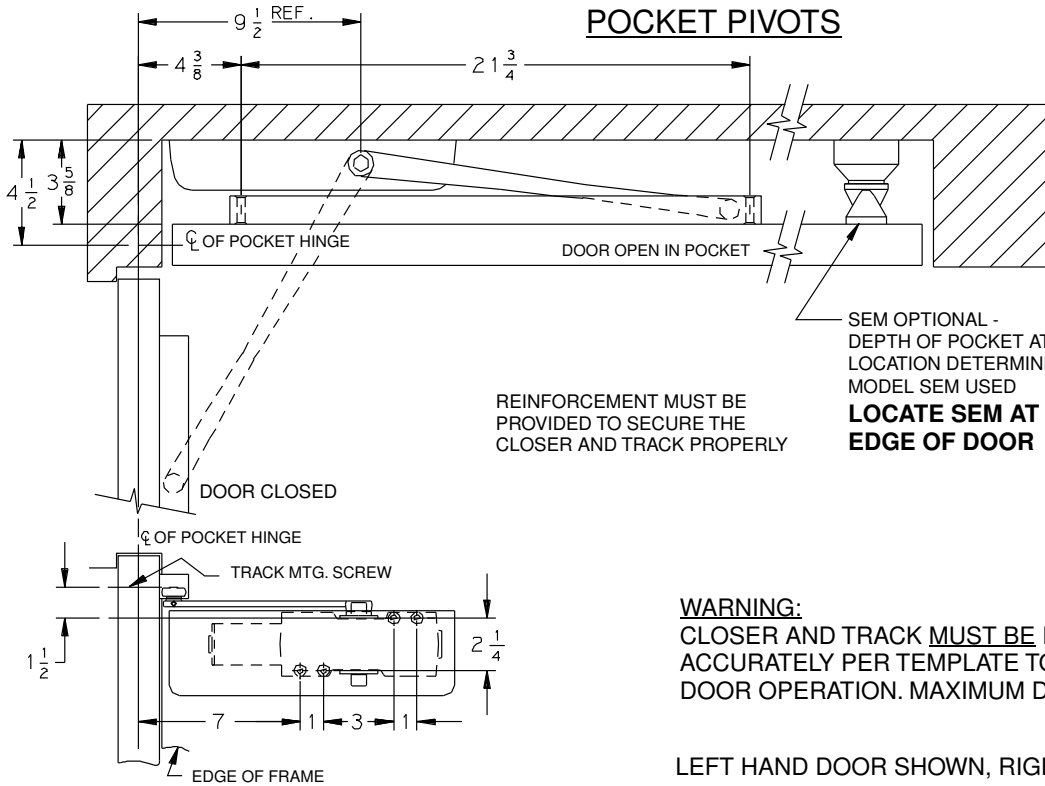

POCKET INSTALLATION APPLIES TO:

4003T } MAX. OPENING 90°
4004T } HOLD OPEN POINT 90°
 } WITH MAGNET

AUXILIARY STOP RECOMMENDED

REINFORCEMENT MUST BE PROVIDED TO SECURE THE CLOSER AND TRACK PROPERLY

SEM OPTIONAL - DEPTH OF POCKET AT THIS LOCATION DETERMINE BY MODEL SEM USED

LOCATE SEM AT LATCH EDGE OF DOOR

WARNING:

CLOSER AND TRACK **MUST BE** INSTALLED ACCURATELY PER TEMPLATE TO ASSURE PROPER DOOR OPERATION. MAXIMUM DOOR HOLD OPEN 90°

LEFT HAND DOOR SHOWN, RIGHT HAND OPPOSITE

TOTAL DOOR HINGE

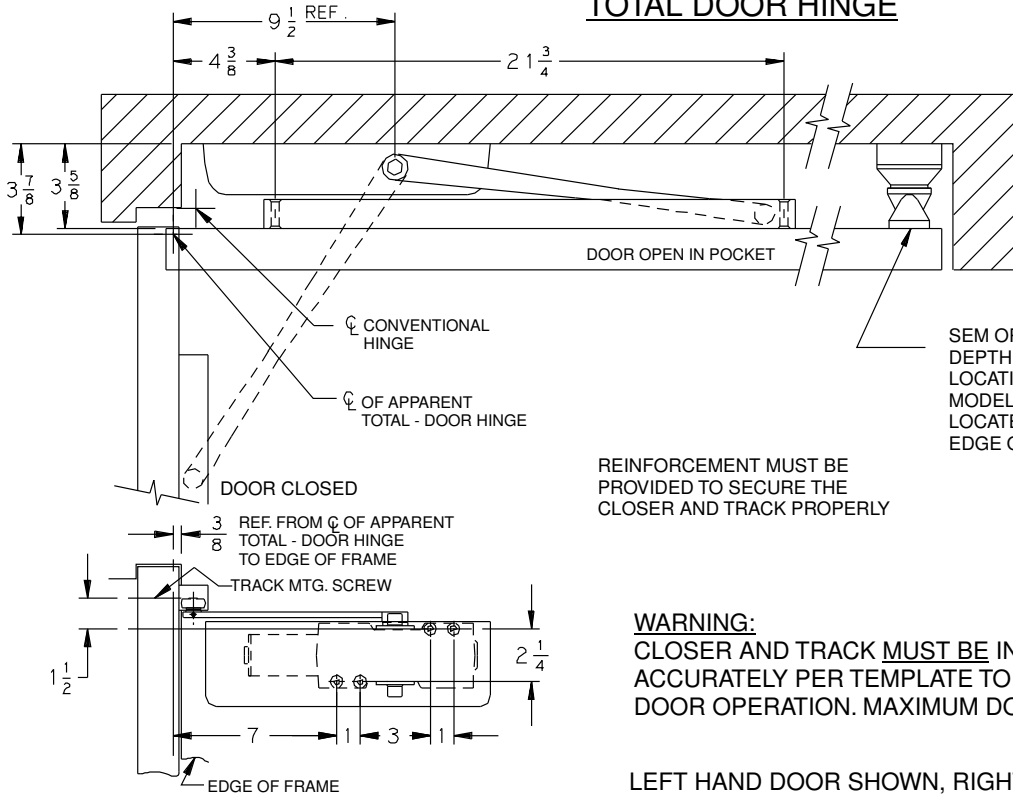

POCKET INSTALLATION APPLIES TO:

4003T } MAX. OPENING 90°
4004T } HOLD OPEN POINT 90°
 } WITH MAGNET

AUXILIARY STOP RECOMMENDED

REINFORCEMENT MUST BE PROVIDED TO SECURE THE CLOSER AND TRACK PROPERLY

SEM OPTIONAL - DEPTH OF POCKET AT THIS LOCATION DETERMINED BY MODEL SEM USED
LOCATE SEM AT LATCH EDGE OF DOOR.

WARNING:

CLOSER AND TRACK **MUST BE** INSTALLED ACCURATELY PER TEMPLATE TO ASSURE PROPER DOOR OPERATION. MAXIMUM DOOR HOLD OPEN 90°

LEFT HAND DOOR SHOWN, RIGHT HAND OPPOSITE

GENERAL NOTES:

1. CLOSER SIZE: 12 1/4 x 3 1/2 x 2 5/32.
2. SPECIAL TEMPLATE FOR USE WITH SWING CLEAR HINGES.
3. REINFORCING PER ANSI/SDI-100 RECOMMENDED FOR HOLLOW DOORS AND FRAMES.

INCH	1/4	3/8	1	1 1/2	2 1/8	2 5/32	2 1/4	2 3/8	2 7/8
M.M.	6	10	25	38	54	55	57	60	73

INCH	3	3 1/2	3 5/8	3 7/8	4 3/8	4 1/2	7	9 1/2	12 1/4	2 1/4
M.M.	76	89	92	98	112	114	178	241	311	552

4000T

PULL SIDE MOUNT FOR 90° INSTALLATION

LCN[®]
1-800-526-2400

STANDARD HINGE

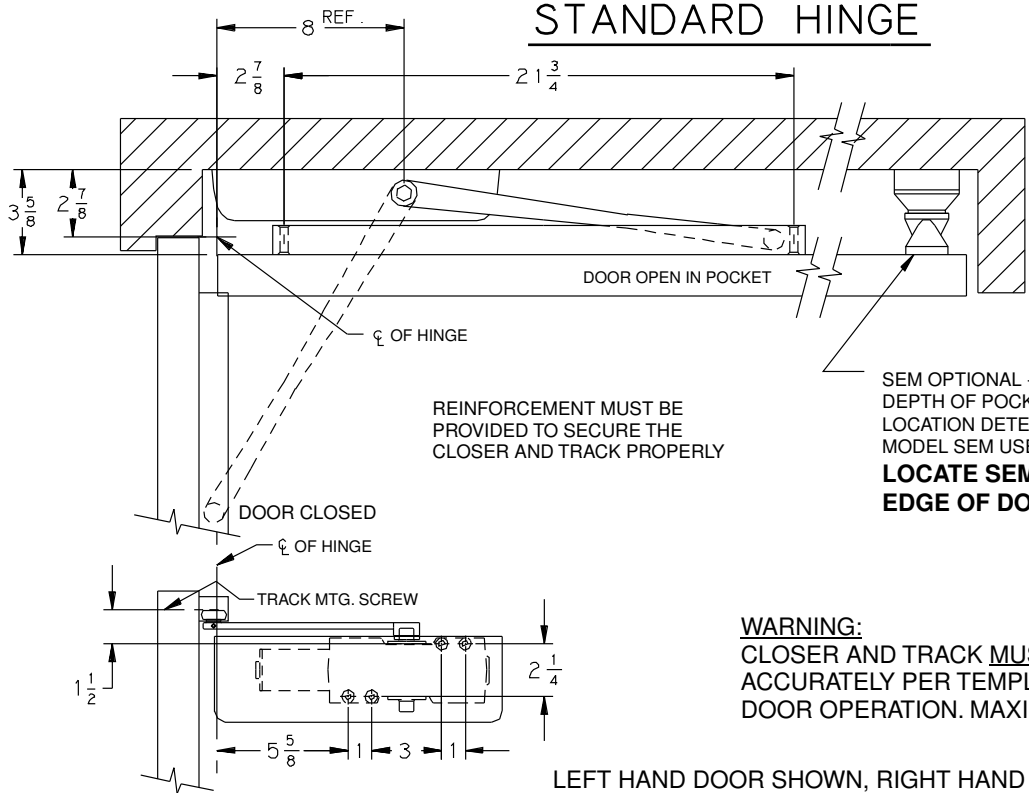

POCKET INSTALLATION APPLIES TO:
 4003T } MAX. OPENING 90°
 4004T } HOLD OPEN POINT 90°
 WITH MAGNET
 AUXILIARY STOP RECOMMENDED

WARNING:
 CLOSER AND TRACK MUST BE INSTALLED
 ACCURATELY PER TEMPLATE TO ASSURE PROPER
 DOOR OPERATION. MAXIMUM DOOR HOLD OPEN 90°

LEFT HAND DOOR SHOWN, RIGHT HAND OPPOSITE

CENTER PIVOT

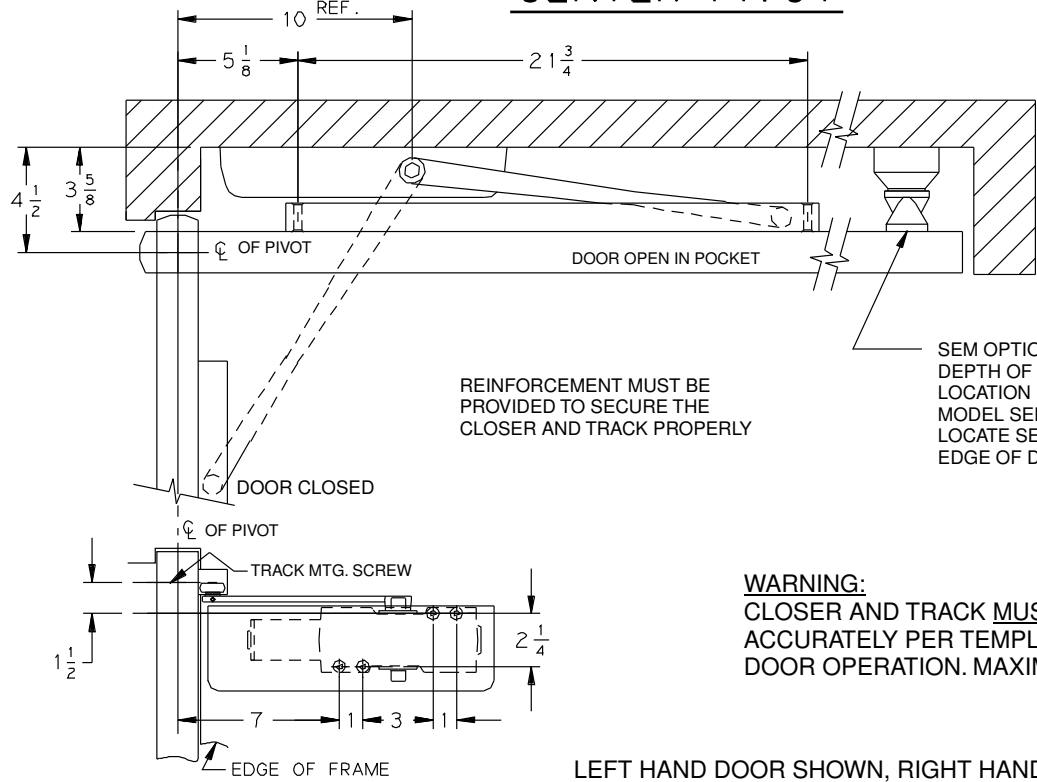

POCKET INSTALLATION APPLIES TO:
 4003T } MAX. OPENING 90°
 4004T } HOLD OPEN POINT 90°
 WITH MAGNET
 AUXILIARY STOP RECOMMENDED

WARNING:
 CLOSER AND TRACK MUST BE INSTALLED
 ACCURATELY PER TEMPLATE TO ASSURE PROPER
 DOOR OPERATION. MAXIMUM DOOR HOLD OPEN 90°

LEFT HAND DOOR SHOWN, RIGHT HAND OPPOSITE

INCH	1/4	3/8	1	1 1/2	2 1/8	2 1/4	2 5/32	2 3/8	2 7/8	3	
M M.	6	10	25	38	54	57	55	60	73	76	
INCH	3 1/2	3 5/8	4 3/8	4 1/2	5 1/8	5 5/8	7	8	10	12 1/4	12 3/4
M M.	89	92	112	114	130	143	178	203	254	311	552

- GENERAL NOTES:**
1. CLOSER SIZE: 12 1/4 x 3 1/2 x 2 5/32.
 2. IF DOOR IS HUNG ON SWING CLEAR HINGES, CONSULT FACTORY.
 3. REINFORCING PER ANSI/SDI-100 RECOMMENDED FOR HOLLOW DOORS AND FRAMES.

4000T
 PULL SIDE MOUNT FOR 90° INSTALLATION



SWING CLEAR HINGE

POCKET INSTALLATION APPLIES TO:

4003T	} MAX. OPENING 90° HOLD OPEN POINT 90° WITH MAGNET
4004T	
AUXILIARY STOP RECOMMENDED	

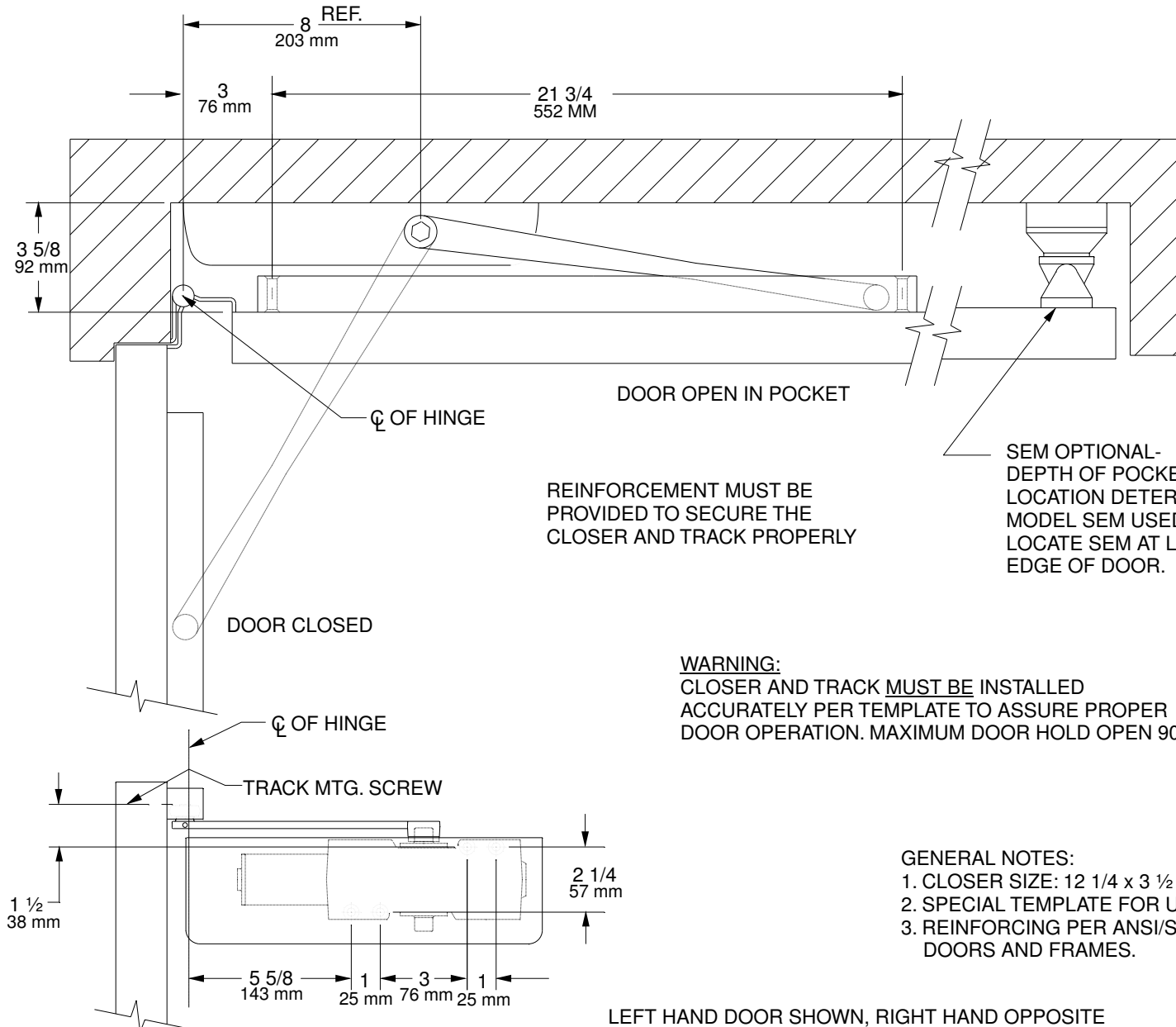

REINFORCEMENT MUST BE PROVIDED TO SECURE THE CLOSER AND TRACK PROPERLY

WARNING:
CLOSER AND TRACK MUST BE INSTALLED ACCURATELY PER TEMPLATE TO ASSURE PROPER DOOR OPERATION. MAXIMUM DOOR HOLD OPEN 90°

- GENERAL NOTES:
1. CLOSER SIZE: 12 1/4 x 3 1/2 x 2 5/32.
 2. SPECIAL TEMPLATE FOR USE WITH SWING CLEAR HINGES.
 3. REINFORCING PER ANSI/SDI-100 RECOMMENDED FOR HOLLOW DOORS AND FRAMES.

LEFT HAND DOOR SHOWN, RIGHT HAND OPPOSITE