

3130SE INSTRUCTION SHEET

INSTALLATION

1. Closer is handed at factory and must match hand of door. Hand of closer shown on mounting channel.
2. Voltage shown on Sentronic® cover plate must match voltage supplied to door frame (24V or 120V).
3. If door and frame are not prepared for closer and track then prepare in accordance with template on opposite side.
4. Remove cover plate from track. Assemble flexible conduit connector to tapped hole provided in top of track. Connect power supply wires to track terminal strip. See wiring diagram below. Insert track into frame and secure with proper screws as shown on opposite side. Replace cover plate, aligning hole with switch.
5. Insert closer into cut - out in door and secure with proper screws.
6. Place arm on closer shaft and secure with arm screw.
7. Loosen set screw in end of arm, open door part way (about 30°), pull arm away from top of door and connect to track roller. Tighten set screw firmly. Open door to hold open position.
8. To place door in desired hold open position, remove arm screw in adjustable arm and re-insert arm screw at new location and tighten.

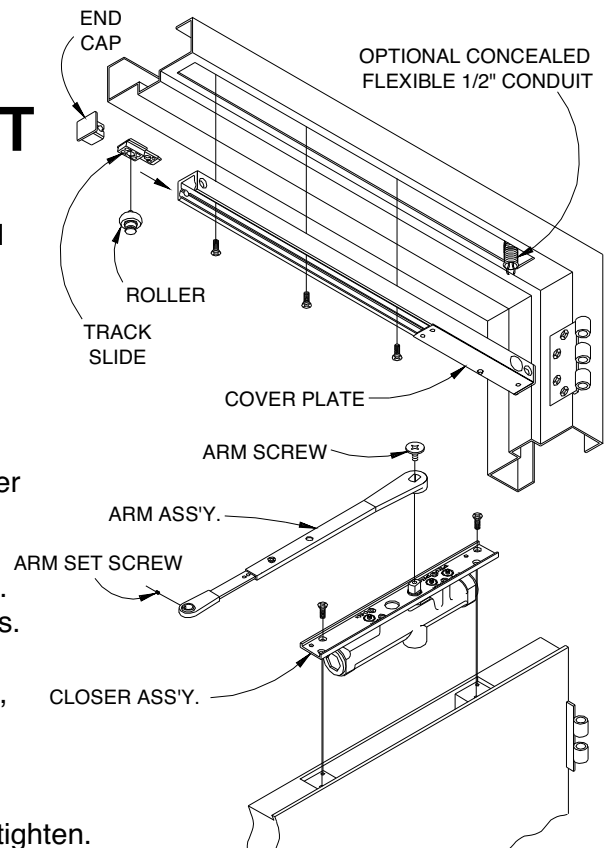

IMPORTANT

REGULATION The 3130 SE door closer is regulated prior to shipment. If adjustments are necessary, use socket screw key furnished to adjust speed. To slow **MAIN SPEED** of door turn **MAIN SPEED** screw clockwise. To slow **LATCH SPEED** of door turn **LATCH SPEED** screw clockwise. To increase **BACKCHECK** turn **BACKCHECK** screw clockwise. Use lightest **BACKCHECK** that will retard door opening sufficiently. Do not use an **ABRUPT BACKCHECK**, nor expect door closer to act as a door stop.

CAUTION IMPROPER INSTALLATION OR REGULATION MAY RESULT IN PERSONAL INJURY OR PROPERTY DAMAGE. FOLLOW ALL INSTRUCTIONS CAREFULLY. FOR QUESTIONS, CONTACT LCN CLOSERS AT: 800-526-2400

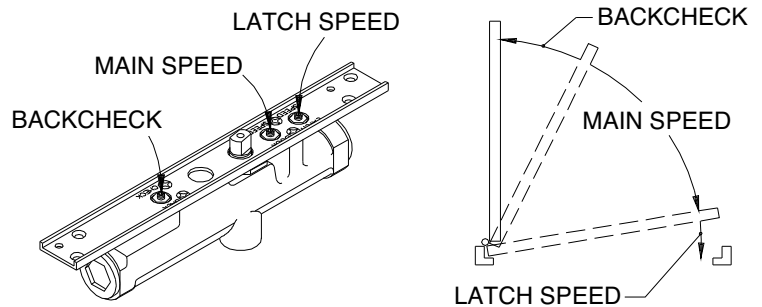

WIRING DIAGRAM - POLARITY NOT IMPORTANT

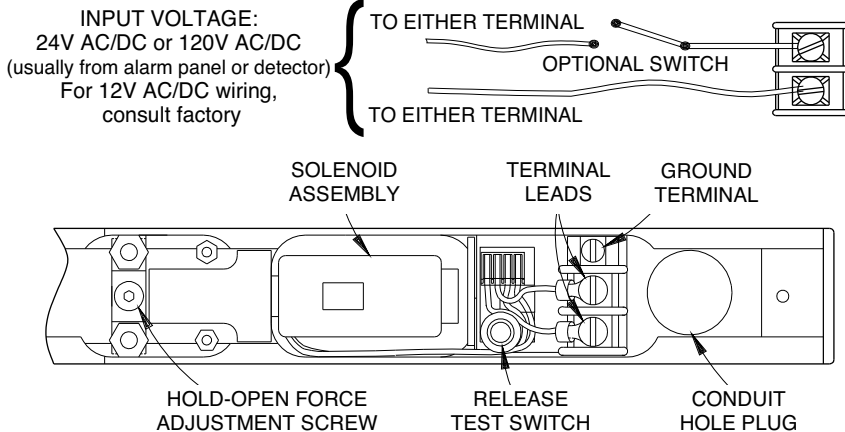

HOLD OPEN FORCE ADJUSTMENT: Locate hold-open adjustment screw in diagram above. For greater hold open force, insert socket screw key wrench (included in screwpack) and turn clockwise. To decrease amount of hold open force, turn screw counter-clockwise. Maximum of 4 turns.

ELECTRICAL CHECKOUT

1. With power on, open door completely. Door should remain in open position. If door does not stay open check electrical input.
2. Push release test switch. Door should close immediately. Open the door to hold-open position and let it remain there.
3. System should be checked at frequent intervals. It is suggested that step 2 be repeated every 90 days.

WARNING HAZARDOUS VOLTAGE CAN SHOCK AND CAUSE SEVERE INJURY

Disconnect power before making any electrical connections or performing maintenance.

3130 SE } 85° to 110° HOLD OPEN

AUXILIARY STOP RECOMMENDED

LEFT HAND DOOR AND CLOSER SHOWN. RIGHT HAND OPPOSITE 8/95

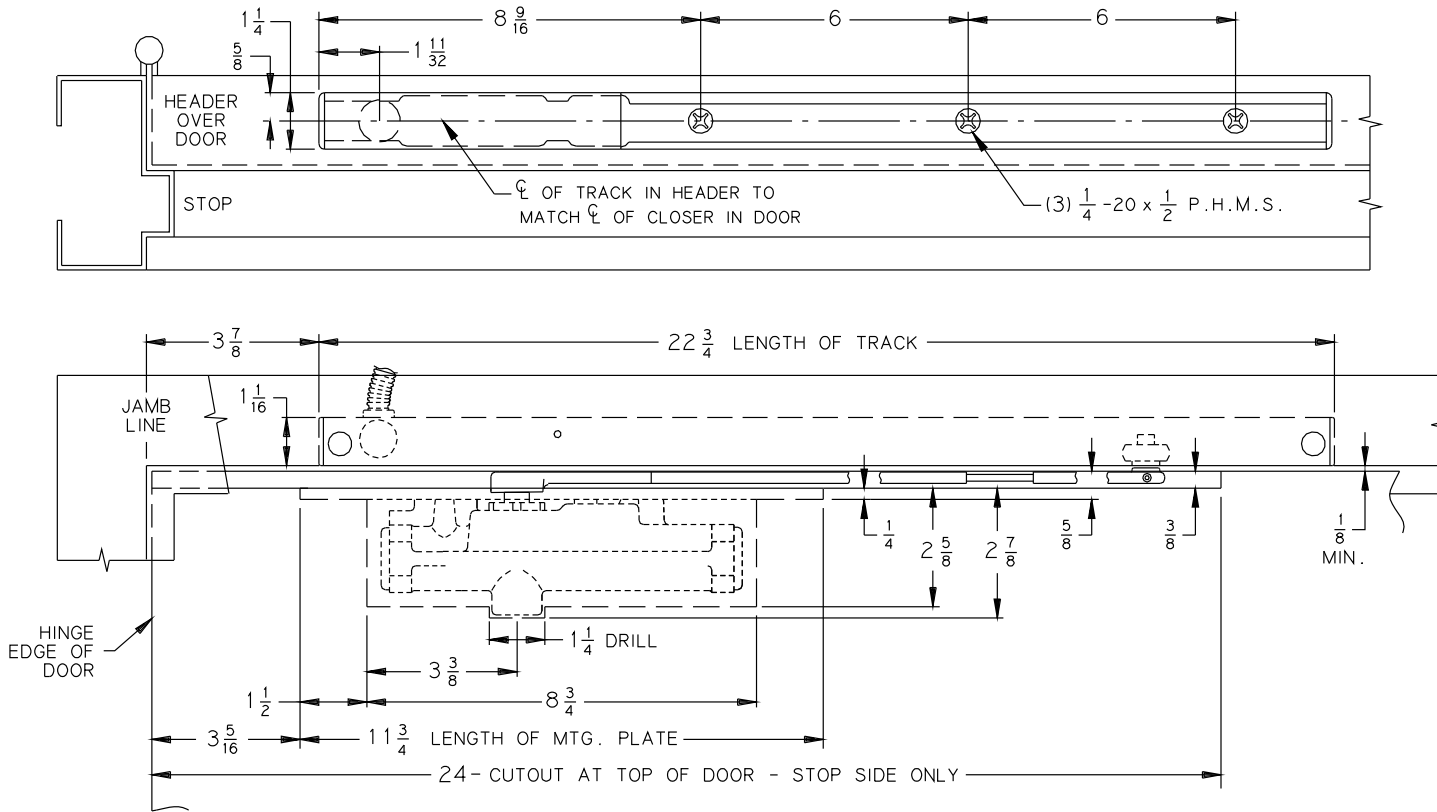

1 1/2 DIA. HOLE IN REINFORCEMENT FOR CONDUIT CONNECTOR CLEARANCE

CL OF DOOR, CLOSER & TRACK

OPTIONAL WIRING CONNECTIONS

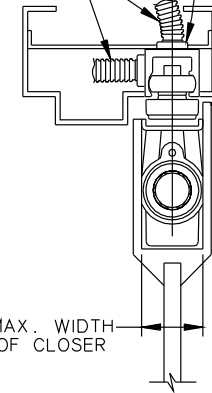

DOOR HOLDER SOLENOID DATA

24 VAC -DC Nom inal+10% -15% @ .090 Amp.Max.
 120 VAC -DC Nom inal+10% -15% @ .030 Amp.Max.
 For 12V wiring consult factory.

NOTES -

1. Voltage supplied to unit MUST match voltage shown on Sentronic® label.
2. If door is hung on pivots or swing clear hinges consult factory.
3. Floor or wall stops must be used.
4. Reinforcing per ANSI SD F-100 is recommended for hollow metal doors and frames.

WARNING

HAZARDOUS VOLTAGE CAN SHOCK AND CAUSE SEVERE INJURY
 Disconnect power before making any electrical connections or performing maintenance.

INCH	1/8	1/4	11/32	3/8	1/2	5/8	11/16	3/4	1	1 1/16	1 1/8	1 1/4	1 11/32	1 3/8
M.M.	3	6	9	10	13	16	18	19	25	27	29	32	34	35
INCH	1 1/2	2 5/8	2 7/8	3 5/16	3 3/8	3 7/8	6	8 9/16	8 3/4	10 5/8	11 3/8	11 3/4	22 3/4	24
M.M.	38	67	73	84	86	98	152	217	222	270	289	298	578	610

No.	REVISION	BY	DATE		DRW BY CTB 5/94 DO NOT SCALE
1	UPDATE CHART	AMM	03/98		
				3130 SE CONCEALED CLOSER \ HOLDER WITH ELECTRONIC RELEASE 3130 SE CONCEALED MOUNTING	