

2610 AUTO-EQUALIZER

LOW ENERGY DOOR OPERATOR INSTALLATION INSTRUCTIONS

CAUTION

IMPROPER INSTALLATION OR
REGULATION MAY RESULT IN
PERSONAL INJURY OR
PROPERTY DAMAGE. FOLLOW ALL
INSTRUCTIONS CAREFULLY. FOR
QUESTIONS, CALL LCN AT
800 - 526 - 2400

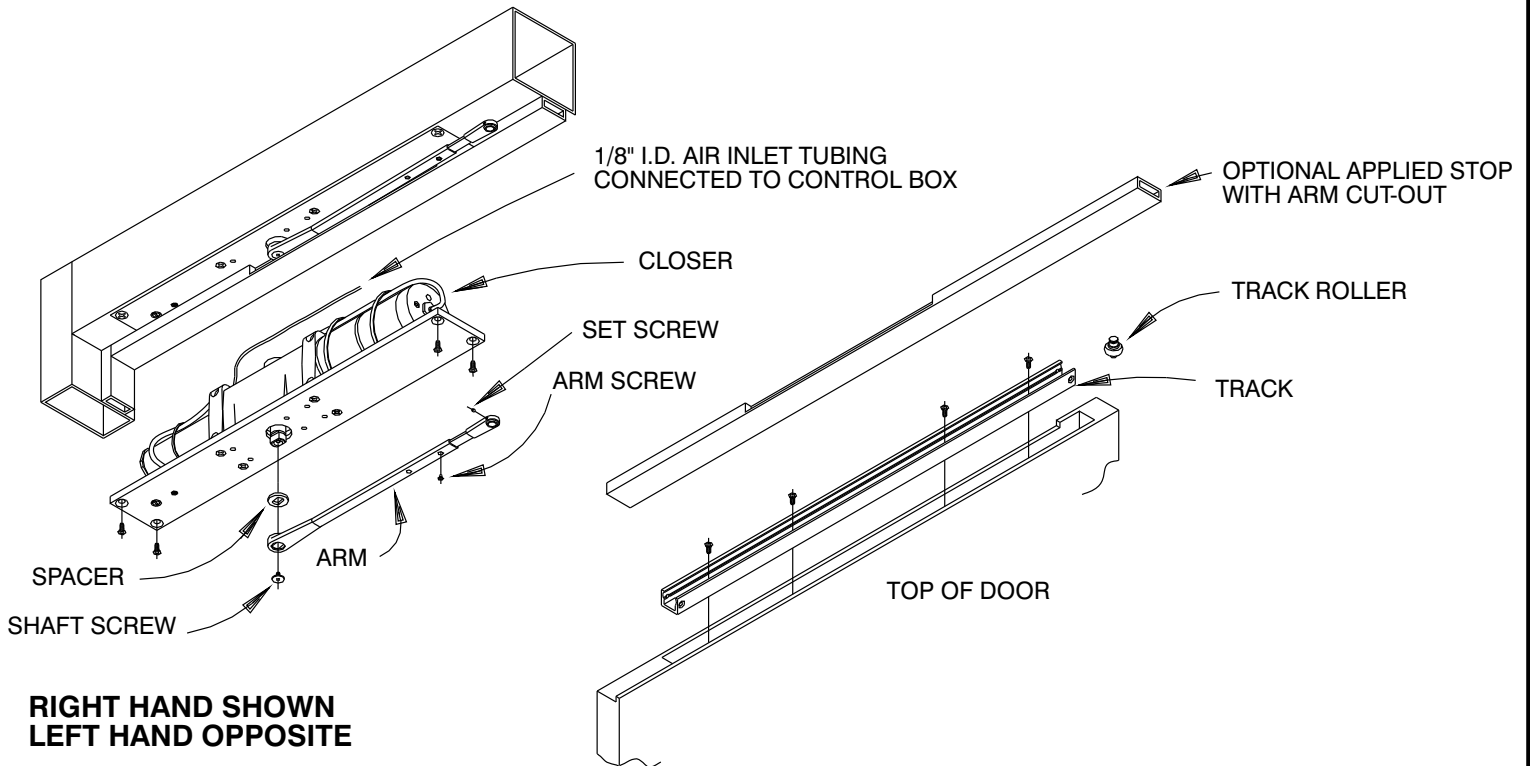

**RIGHT HAND SHOWN
LEFT HAND OPPOSITE**

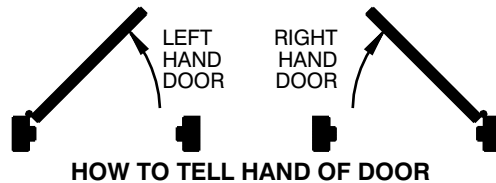

INSTALLATION

1. Closer is handed at factory and must match hand of door. Hand of closer is stamped on mounting plate.
2. If frame and door are not prepared for closer and track, see template (page 5) for required installation and prepare according to details shown.
3. Connect air line to closer at speed control valve inlet fitting.
4. Insert closer in prepared frame and fasten with screws provided.
5. Insert track roller in track and mount track in prepared door opening with screws provided.
6. Place spacer on closer shaft. Then push arm over shaft and secure with shaft screw.
7. Loosen set screw in end of arm using a 3/32" hex wrench. Open door part way (30°-40°), pull arm over top of door and connect to track roller. Tighten set screw firmly.

NOTE: If door is hung on pivots, swing clear, or wide throw hinges, consult factory.

CLOSING FORCE ADJUSTMENT (See Illustration A)

1. Closer is shipped with minimum closing power pre-set. Adjust CLOSING POWER only if more power is needed.
2. To increase closing power turn spring adjustment screw, using regular screw driver, clockwise. Maximum adjustment is 18 turns.

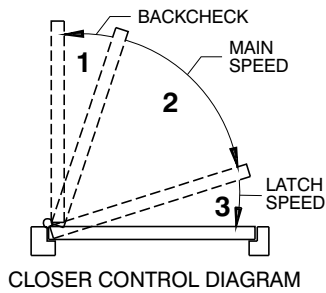
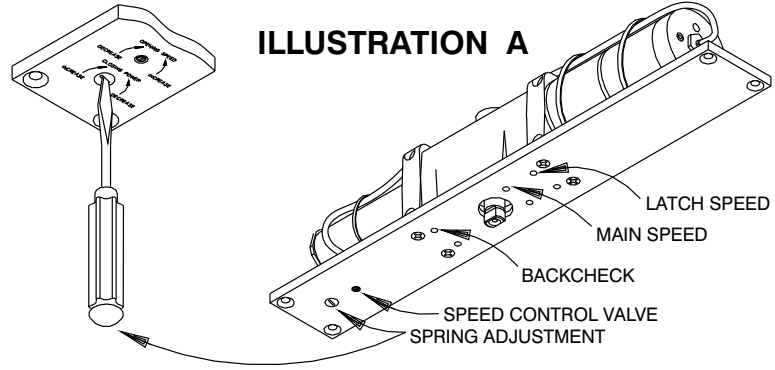

ILLUSTRATION B



CLOSING SPEED ADJUSTMENT (See Illustration B)

1. Do not allow door to slam into frame.
2. A "normal" closing time from 90° open position is 5 to 7 seconds, evenly divided between **MAIN SPEED** and **LATCH SPEED**.
3. Use a 3/32" hex wrench to adjust speed.
4. To slow **MAIN SPEED** of door, turn regulating screw (nearest closer shaft) clockwise.
5. To slow **LATCH SPEED** of door, turn regulating screw (nearest latch) clockwise.

OPENING SPEED ADJUSTMENT

NOTE: FOR AIR PRESSURE REGULATION, SEE CONTROL BOX INSTRUCTION SHEET.

1. The door opening speed must be adjusted to suit the width and weight of the door. The wider and/or heavier the door, the slower it should open. To determine opening speed, measure door leaf width and weight. If door weight cannot be measured, the weight can be estimated by finding the area of the door (length x width) and multiplying it by the weight per square foot for the door type that is being used as shown below in Table 2.

TABLE 2

DOOR TYPE	Weight per sq. ft.
Solid Core Wood 20 Ga. Flush Hollow Metal Aluminum x 1" Glass	5.5
Mineral Core Door 16 Ga. Flush Hollow Metal Aluminum x 1" Glass	7.0

NOTE:

These weights are for 1 3/4" thick doors. If the doors are thicker or thinner, consult door manufacturer for proper weight OR weigh the door.

2. The door opening speed is measured from closed door to 80° or backcheck (see closing speed adjustments). At 80°, the edge of a 36" door is approximately 6" from a right angle. (See Illustration C.)
3. The opening speed control adjusting screw is located near the end of the mounting plate directly below the tubing connections. (See Illustration A). Using a regular screwdriver, turn the speed control clockwise to slow the door speed, counter-clockwise to increase door speed. Set speed to open door from 0° to 80° as shown in Table 3 below.

ILLUSTRATION C

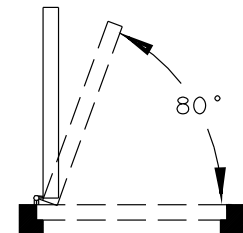

TABLE 3

Door Weight In Pounds	FASTEST OPENING TIME IN SECONDS TO 80° POSITION		
	Door Width In Inches		
	36"	42"	48"
100 lbs.	3.0 sec.	3.0 sec.	3.0 sec.
125 lbs.	3.5 sec.	3.5 sec.	3.5 sec.
150 lbs.	3.5 sec.	3.5 sec.	3.5 sec.
200 lbs.	4.0 sec.	4.0 sec.	4.0 sec.



NOTE:

If door width or weight is between the sizes and pounds listed, use time shown for the next wider or heavier door.

BACKCHECK ADJUSTMENT

1. Backcheck slows down the door swing as it approaches full opening (See Illustration B on page 2).
2. Increase the resistance of backcheck ONLY if necessary to prevent the door from striking a wall. To do this, turn the regulating screw nearest the hinge clockwise by quarter turns. DO NOT USE AN ABRUPT BACKCHECK.

HOLD OPEN TIME ADJUSTMENT

1. After opening, the door should remain at the 90° position for no less than 5 seconds. This "Hold Open Time" can be increased to approx. 30 seconds by turning the timer adjustment wheel(s) clockwise. For the location of this wheel(s), refer to 7900 or 7980 series Control Box Instruction Sheet. Adjust "Hold Open Time" to maximum practical for the elderly or severely handicapped. Time cycle begins when the switch or scanner is released.

DOOR SIGNAGE

1. Refer to local approving authority for required signage (decals) and positioning.
2. LCN's recommendation is:
 - a. Position decal(s) furnished with actuator(s) where it can be viewed without interference from door trim, panic devices, etc. near the lock stile (48" max.-15" min.) above the floor.
 - b. Clean area 6" x 6" where decal(s) will be placed.
 - c. Apply decal(s) to same side of door where switch(s) will be installed. NOTE: DECALS MAY BE DIFFERENT. Remove backing and "roll" onto door to avoid trapping air under decal(s).

SINGLE LEVEL ARM SCREW ADJUSTMENT

1. It may be necessary to adjust the fully open door position. Minor adjustment for more or less opening can be obtained by using the telescoping arm as follows: (See Illustration D)
 - a. Shorten length of arm to decrease door opening.
 - b. Lengthen arm to increase door opening.
 - c. Tighten arm screw securely after adjustment.
 - d. After arm adjustment is made, cycle door to insure that it is operating properly.

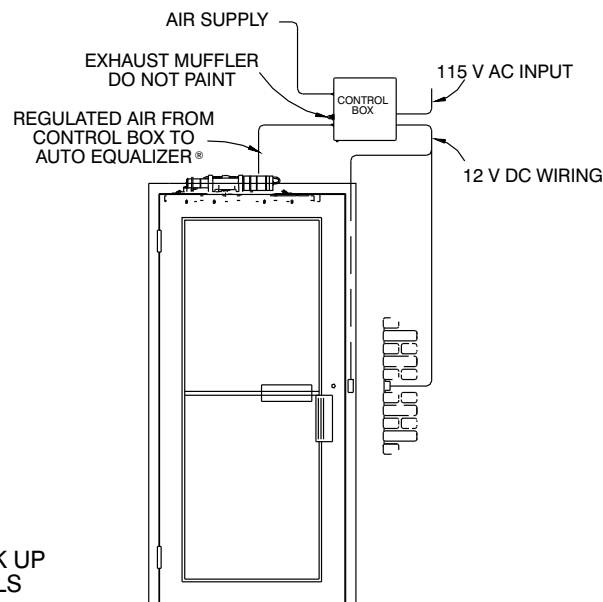
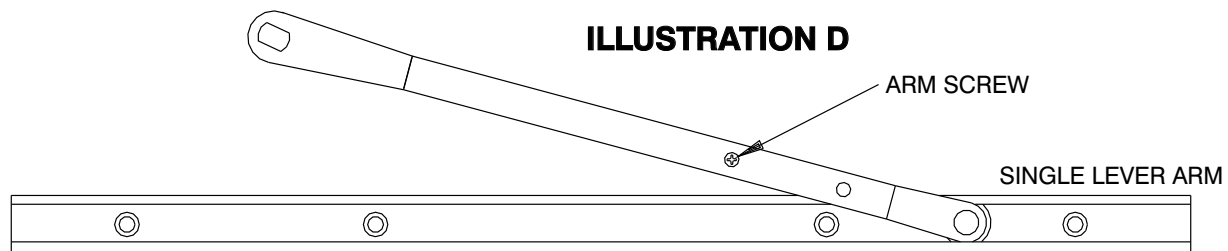

TYPICAL ELECTRIC AND AIR HOOK UP
FOR SWITCH-ACTUATED MODELS

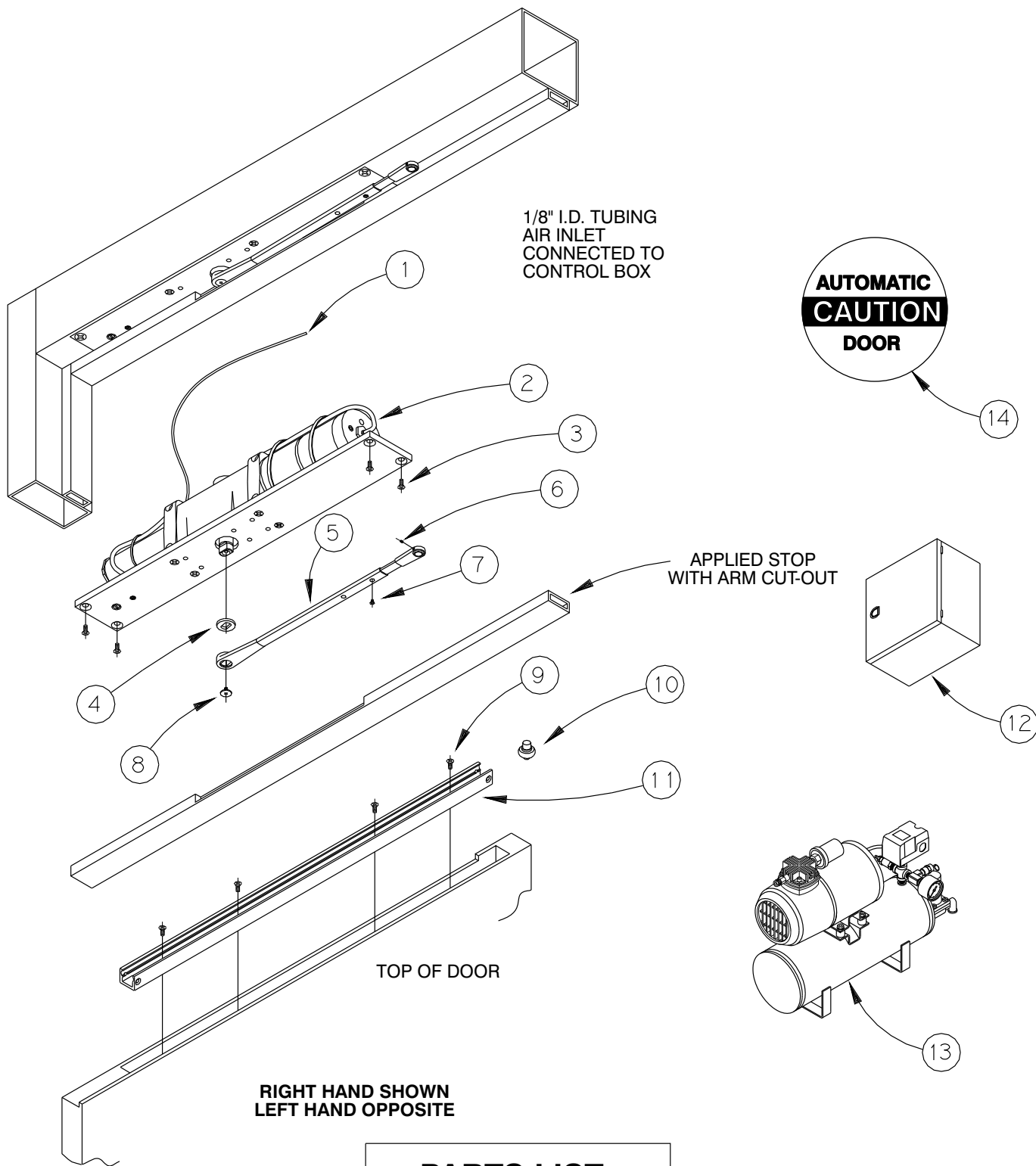

PARTS LIST

Item	Part Number	Description	Item	Part Number	Description
1	925	1/8" I.D. Pneumatic Tubing	8	4010-159	Shaft Screw
2	2613 OR 2614	LCN switch-Activated Auto Equalizer	9	No. 14 x 1" No. 1/4-20 x 1/2"	Phillips Head Wood Screws Phillips Head Machine Screws
3	No. 1/4-20 x 5/8"	Phillips Head Machine Screw	10	2010-3034	Track Roller Assy.
4	4910-61	Spacer	11	2610-38	Track
5	2610-3035	Arm (Specify L.H. or R.H.)	12	7900 or 7980 Series	Control Box
6	2014-30	Set Screw	13	920 or 921	Compressor (Optional)
7	No. 10-24 x 3/8"	Arm Screw	14	4820-155G	Decal

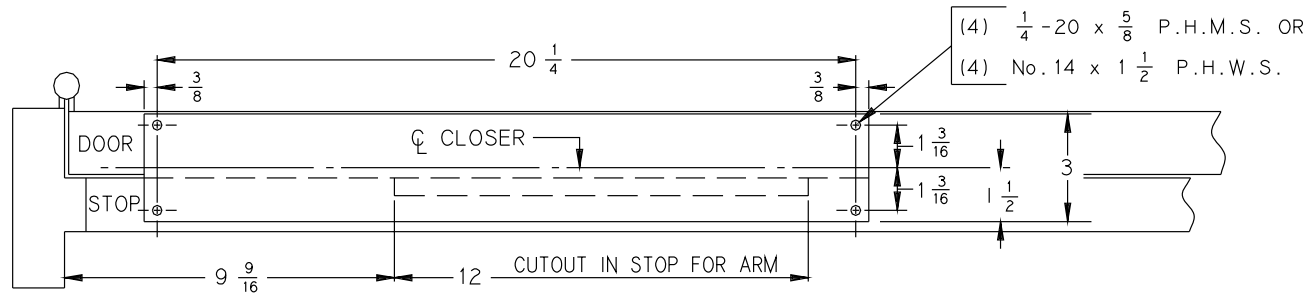

2613 } 90° POWER OPENING
 2614 } 160° MAX. OPENING

AUXILIARY STOP RECOMMENDED

LEFT HAND DOOR AND CLOSER SHOWN, RIGHT HAND OPPOSITE 6/96

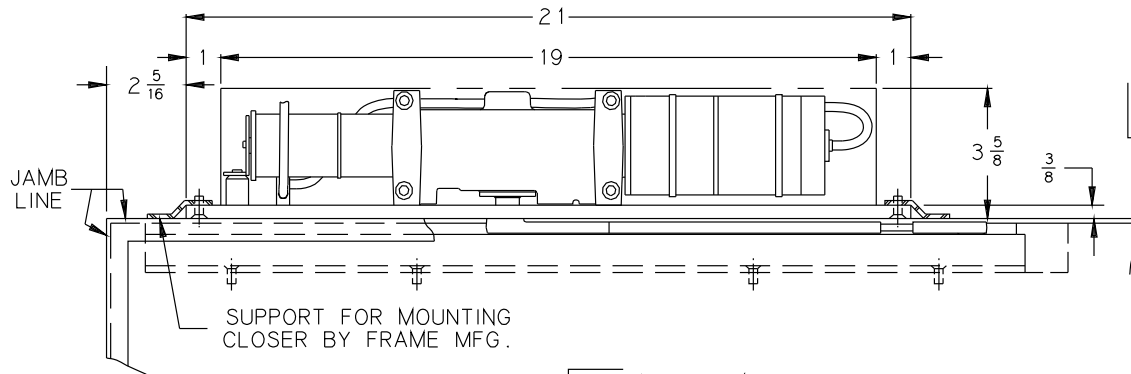

MINIMUM SPACE REQUIRED FOR CLOSER ARM IN STOP MUST BE $\frac{1}{2}$ x $\frac{1}{2}$. IT MAY BE INCREASED IF DESIRED.

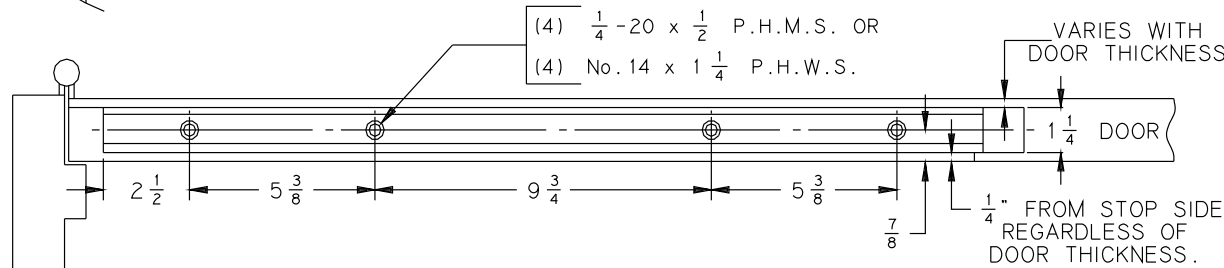
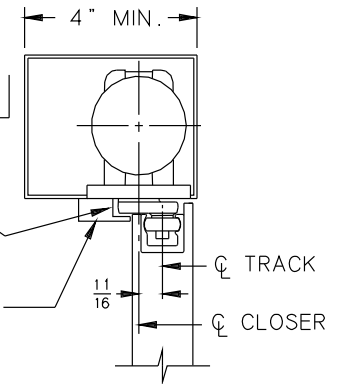

NOTES-

- 1 - MINIMUM STOP THICKNESS $\frac{1}{2}$ ".
- 2 - $\frac{1}{8}$ " DOOR TO SOFFIT CLEARANCE REQUIRED.
- 3 - $\frac{1}{8}$ " I.D. TUBING CONNECTED TO CONTROL BOX.
- 4 - REINFORCING PER ANSIXSDI-100 RECOMMENDED FOR HOLLOW METAL DOOR & FRAMES.
- 5 - MAXIMUM ALLOWABLE BUTT SIZE IS 5" x 5".
- 6 - IF DOOR IS HUNG ON PIVOTS CONSULT FACTORY.

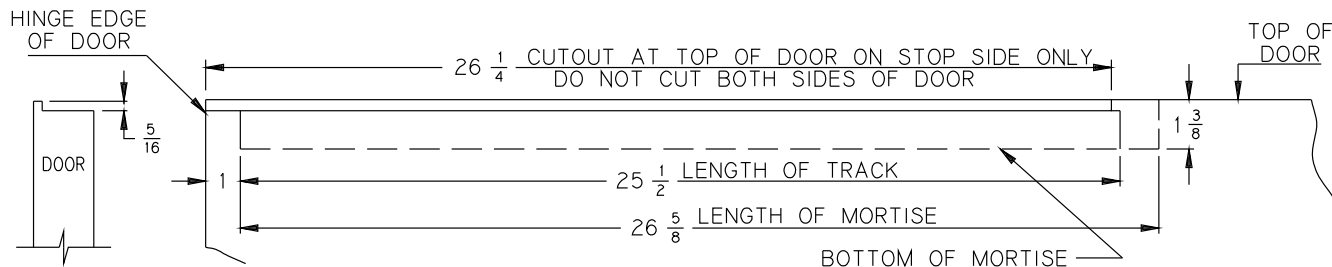

CUTOUT FOR ARM INCLUDES HEEL OF DOOR AS SHOWN

PLAN & ELEVATION OF TOP OF DOOR SHOWING PREPARATION FOR CLOSER TRACK

inch	$\frac{1}{8}$	$\frac{1}{4}$	$\frac{5}{16}$	$\frac{3}{8}$	$\frac{1}{2}$	$\frac{5}{8}$	$\frac{11}{16}$	$\frac{7}{8}$	1	$1\frac{3}{16}$	$1\frac{1}{4}$	$1\frac{3}{8}$	$1\frac{1}{2}$	$2\frac{5}{16}$	$2\frac{1}{2}$
mm	3	6	8	10	13	16	17	22	15	30	32	35	38	59	64
inch	3	$3\frac{5}{8}$	4	5	$5\frac{3}{8}$	$9\frac{9}{16}$	$9\frac{3}{4}$	12	19	$20\frac{1}{4}$	21	$25\frac{1}{2}$	$26\frac{1}{4}$	$26\frac{5}{8}$	
mm	76	92	102	127	137	243	248	305	483	514	533	648	667	676	

No.	REVISION	BY	DATE	LCN [®]	APP BY JEJ 6/96
2	TEMPLATE UPDATE	JEJ	6/96		DO NOT SCALE
				OVERHEAD CONCEALED / SINGLE LEVER ARM / AUTO-EQUALIZER [®] CLOSER	
					2610