

# 2310-ME Sentronic<sup>®</sup> INSTRUCTION SHEET

IF CLOSER HAS OPTIONAL HOLD-OPEN BYPASS FEATURE, BYPASS LABEL WILL BE ON CYLINDER

- 1 Closer handed at factory and must match hand of door.  
Hand of closer stamped on finish plate.
- 2 Voltage shown on box label must match voltage supplied to door frame.
- 3 If door & frame are not prepared for closer & track, prepare according to details on opposite side.
- 4 A. Remove finish plate and wiring cover from closer.  
B. Assemble flexible conduit connector to conduit mounting bracket.  
C. Connect input voltage to plug leads as shown in wiring diagram at bottom left.  
D. Replace wiring cover.  
E. Insert closer into frame and secure with proper screws.  
F. Replace finish plates.
5. Insert track roller into track. Insert track in door cut out and secure with proper screws.
6. Place arm on closer shaft and secure with shaft screw.
7. Loosen set screw in end of arm, open door part way (about 30°), pull arm over top of door and connect to track roller. Tighten set screw firmly.

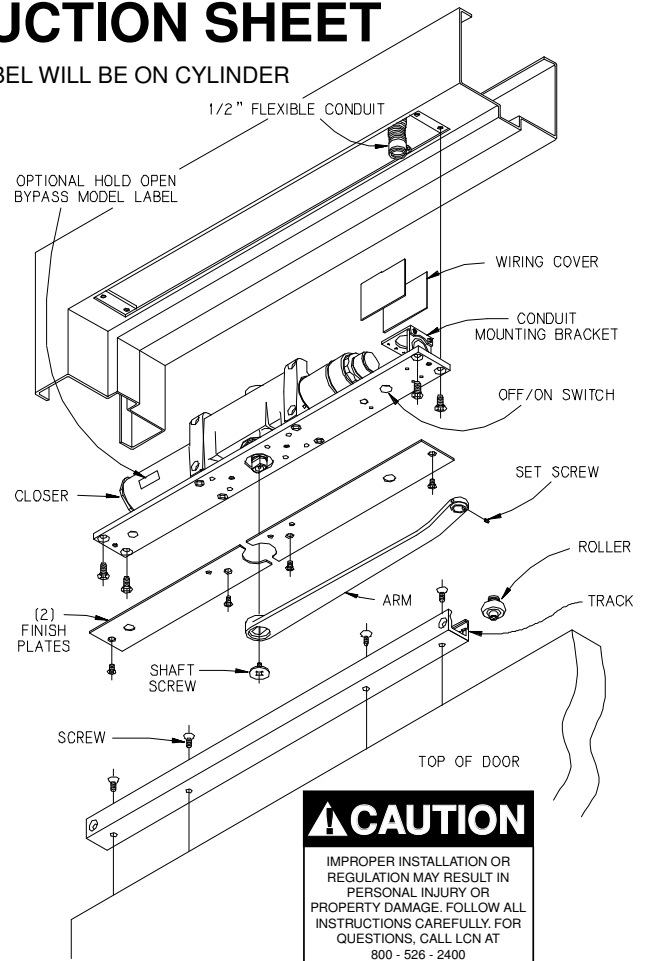

**CAUTION**  
IMPROPER INSTALLATION OR REGULATION MAY RESULT IN PERSONAL INJURY OR PROPERTY DAMAGE. FOLLOW ALL INSTRUCTIONS CAREFULLY. FOR QUESTIONS, CALL LCN AT 800-526-2400

## 8. REGULATION

Do not allow door to slam into frame. A "normal" closing time from 90° open position is 5 to 7 seconds. Use socket screw key furnished. To slow MAIN SPEED of door, turn regulation screw (nearest arm) clockwise. To slow LATCH SPEED of door, turn regulating screw (nearest latch) clockwise.

### BACKCHECK

To increase BACKCHECK, turn regulating screw (nearest hinge) clockwise. Using lightest BACKCHECK that will retard door opening sufficiently.

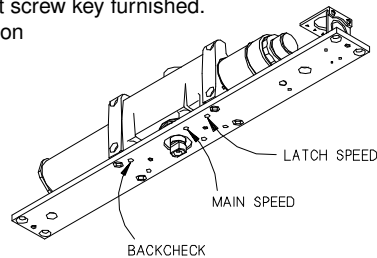

DO NOT USE AN ABPURT BACKCHECK  
NOR EXPECT DOOR CLOSER TO ACT AS DOOR STOP

## 9 CLOSING POWER

Adjust CLOSING POWER only if more power is needed. Closer is shipped with minimum closing power pre-set. To increase CLOSING POWER turn spring adjusting screw clockwise. Maximum adjustment of 18 turns.

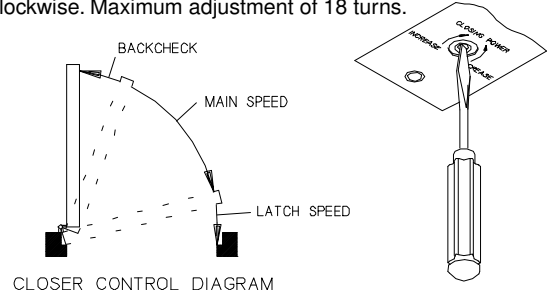

## 10 ELECTRICAL CHECKOUT

- A. With power on, open the door any position and release. The door should remain in the hold-open position within 10°. For a bypass model to hold open, the door must be opened beyond degree of door swing indicated on label.
- B. If not, push on/off switch.
- C. If door does not stay open, verify electrical input in wiring diagram at right.
- D. Turn power off, door should close completely.
- E. To release hold open manually, pull door firmly. Door should close completely under power of closer.
- F. System should be checked at regular intervals. It is suggested that steps A & D be repeated every 90 days.

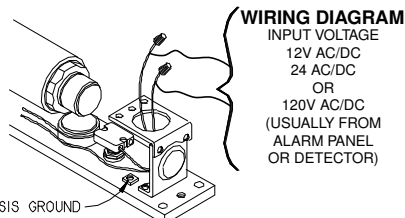

## 11 HOLDING FORCE ADJUSTMENT

IF DOOR IS HARD TO PULL OUT OF HOLD OPEN, ADJUST AS SHOWN.

Holding Force is at maximum. This can be decreased and increased again but not increased beyond original setting.

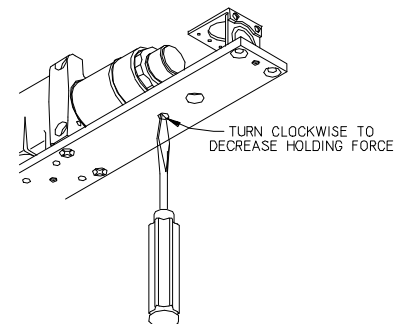

**LCN**<sup>®</sup>  
1-800-526-2400

# 2310 ME

2313 ME } HOLD OPEN ANY POINT TO 170°  
 2314 ME } HOLD OPEN BYPASS UP TO 160°

AUXILIARY STOP RECOMMENDED

LEFT HAND DOOR AND CLOSER SHOWN, RIGHT HAND OPPOSITE 12/96

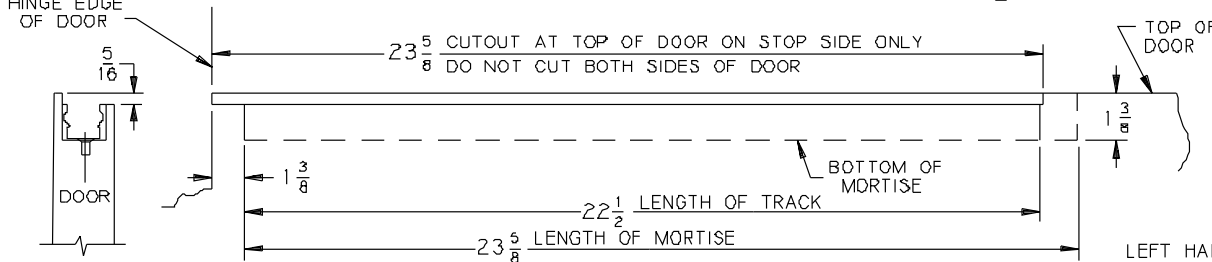
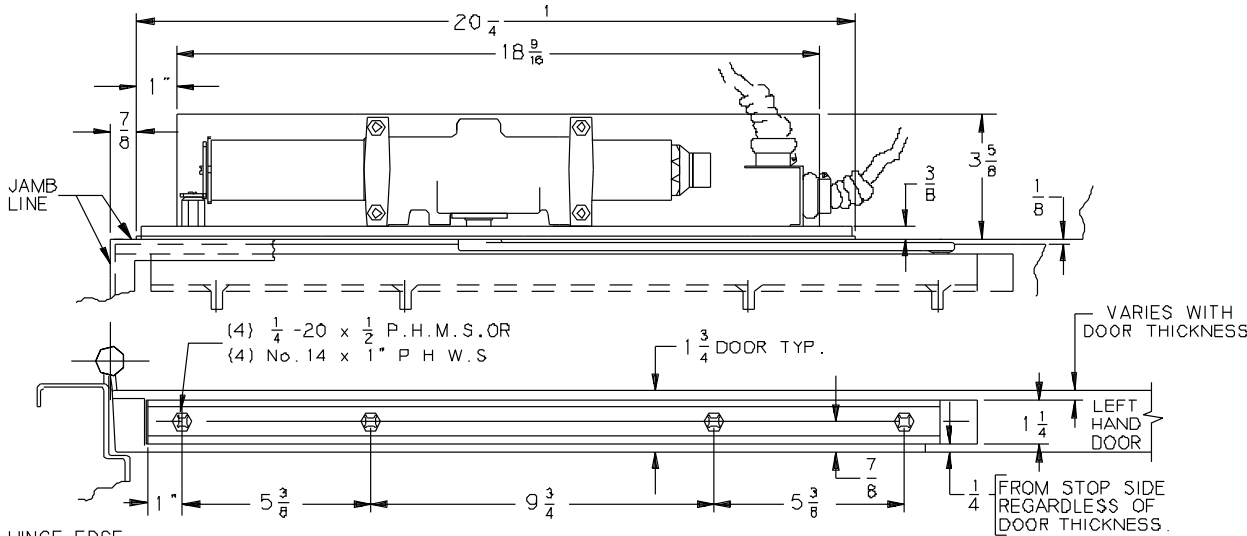
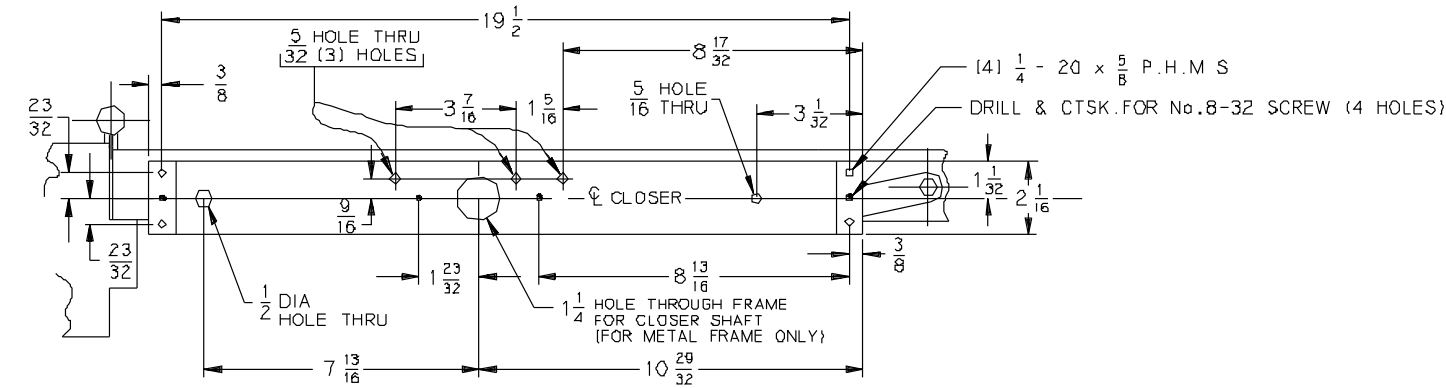

PLAN & ELEVATION OF TOP OF DOOR SHOWING PREPARATION FOR CLOSER TRACK

ON METAL FRAMING, THE SECTION OF SOFFIT & STOP AT CLOSER MUST BE REMOVABLE. THIS SECTION MUST BE SUPPLIED BY THE FRAME MFR. TO INSURE CONFORMITY WITH REMAINDER OF THE FRAME. CONTOUR OF FRAME MAY VARY FROM THAT SHOWN.

CLOSER COVER BOX BY FRAME MANUFACTURER

NOTE: THIS PRODUCT REQUIRES A 4" MIN. FRAME HEADER. CONSULT FACTORY IF HEAD JAMB IS LESS THAN 4".



1/4" DIMENSION MAY BE INCREASED TO 7/8" TO ACCOMMODATE VARYING WALL THICKNESS. SUBMIT DETAILS TO LCN CLOSERS FOR SPECIAL INSTRUCTIONS.

### GENERAL NOTES:

- 1 - FOR 180° OPENINGS, MAX. ALLOWABLE BUTT SIZE IS 5" x 5".
- 2 - MINIMUM STOP THICKNESS 1/2".
- 3 - 1/8" DOOR TO SOFFIT CLEARANCE REQUIRED.
- 4 - FOR METAL FRAMES ONLY.
- 5 - VOLTAGE SHOWN ON SENTRONIC LABEL MUST MATCH VOLTAGE SUPPLIED.
- 6 - FLOOR OR WALL STOP RECOMMENDED.
- 7 - REINFORCING PER ANSI/SDI-100 RECOMMENDED FOR HOLLOW METAL DOOR AND FRAMES.

LEFT HAND DOOR AND CLOSER SHOWN, RIGHT HAND OPPOSITE

INCH	1/8	3/32	1/4	5/16	3/8	1/2	9/16	5/8	23/32	7/8	1	1 1/32	1 1/4	1 5/32	1 3/8	1 3/4	
M M	3	3	6	8	10	13	14	16	18	22	25	26	32	33	33	35	44
INCH	1 3/4	2 1/8	3 1/8	3 7/16	3 5/8	5	5 3/8	7 13/16	8 17/32	8 13/16	9 3/4	10 29/32	11 1/4	11 9/16	12 1/4	12 1/2	13 5/8
M M	44	52	77	87	92	127	137	198	217	224	248	277	464	495	514	572	600

# LCN®