

# INSTRUCTIONS FOR 2210DPS SERIES TEST KIT

## TEST KIT

1. Remove finish plates of the 2210DPS as shown in Fig. 1.
2. Pull field wiring connector through slot in 2210DPS mounting plate and disconnect. (shown in Fig. 2.)
3. Connect Test Kit to 2210DPS as shown in Fig. 3. Red LED light will light indicating a door open or unsecured condition.
4. Push connectors back up through slot and drape ribbon wire over top of door allowing door to close. (shown in Fig.4.)
5. Move door slowly towards closed position. Green LED light will light when door reaches the secure response position. Typically factory setting will be 1/4" to 3/4" off the stop on a 36" door.
6. If 2210DPS response setting is acceptable, disconnect the Test Kit, reconnect the Field Wiring connector, push connectors back up through slot and reinstall the finish cover plates.
7. If a different response position is required, follow steps on back page to adjust the signal response point. When response setting is acceptable, disconnect the Test Kit, reconnect the Field Wiring connector, push connectors back up through slot and reinstall the finish cover plates.

Fig. 1

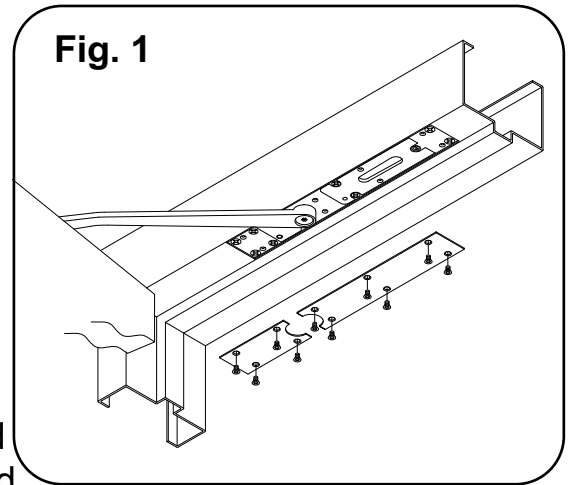

Fig. 2

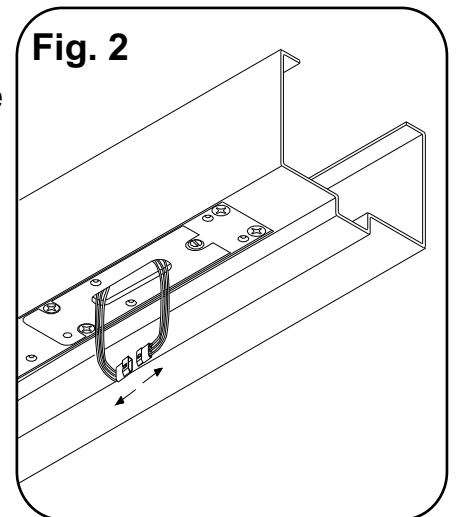

Fig. 3

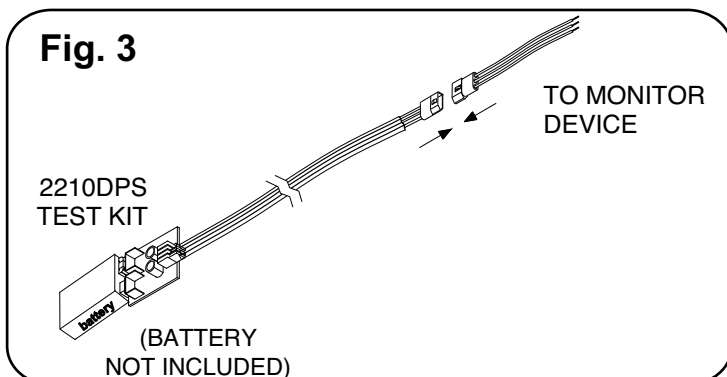
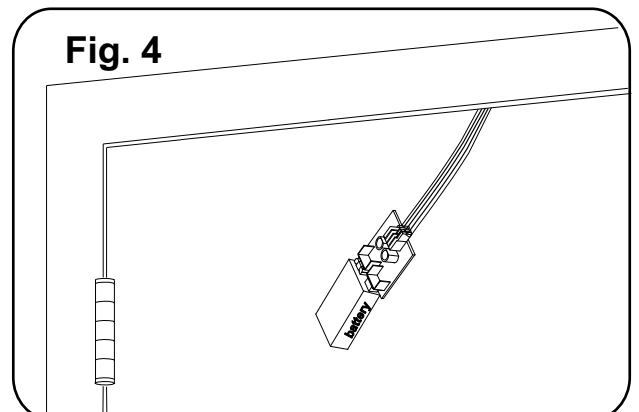

Fig. 4



**FOR 2210DPS: SIGNAL RESPONSE POINT VERIFICATION** If door silencers are to be used, they should be installed prior to this step. Close the door slowly and note where the switch response signal occurs. The factory setting should provide a signal response between 1/4" & 3/4" off the stop for a 36" door.

**Only** if a different signaling point is necessary, perform steps 1A - 1C using a No. 3 Phillips screwdriver (5/16" shank). **If the switch is giving an "open" signal when the door is fully closed, follow steps 1D through 1F.**

To adjust the signaling point for the door **nearer** to the closed position:

**1A.** Open the door approximately 20°, or enough to access the signal adjustment hole in mounting plate (See **Fig. 5**, below). Prevent door from moving during the adjustment. Insert the No. 3 Phillips screwdriver into the signal adjustment hole to engage the trigger gear.

**1B. FOR RIGHT HAND DOOR**  
Turn the screwdriver clockwise  
**VERY SLIGHTLY**

**FOR LEFT HAND DOOR**  
Turn the screwdriver counterclockwise  
**VERY SLIGHTLY**

**1C. REMOVE SCREWDRIVER BEFORE ALLOWING DOOR TO MOVE.** Allow the door to close completely. Check the signal activation point. If still too far from the "door closed" position, repeat steps 1A, 1B & 1C.

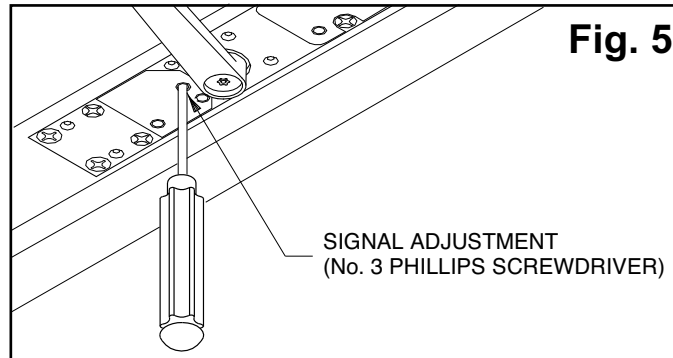

To adjust the signaling point for the door **farther** from the closed position:

**1D.** Open the door approximately 20°, or enough to access the signal adjustment hole in mounting plate (See **Fig. 5**). Prevent door from moving during the adjustment. Insert the No. 3 Phillips screwdriver into the signal adjustment hole to engage the trigger gear.

**1E. FOR RIGHT HAND DOOR**  
Turn the screwdriver counterclockwise  
**VERY SLIGHTLY**

**FOR LEFT HAND DOOR**  
Turn the screwdriver clockwise  
**VERY SLIGHTLY**

**1F. REMOVE SCREWDRIVER BEFORE ALLOWING DOOR TO MOVE.** Allow the door to close completely. Check the signal activation point. If still too close to the "door closed" position, repeat steps 1D, 1E & 1F.