

1000 SERIES

PRODUCT SELECTION GUIDE

Surface mounted 1000 Series LCN closers feature a modern slim line design for easy installation on narrow head frames and top rails. This guide is based on the desired mounting of the closer. NOTE: For parallel mounts order "P" version to also receive PA Shoe.

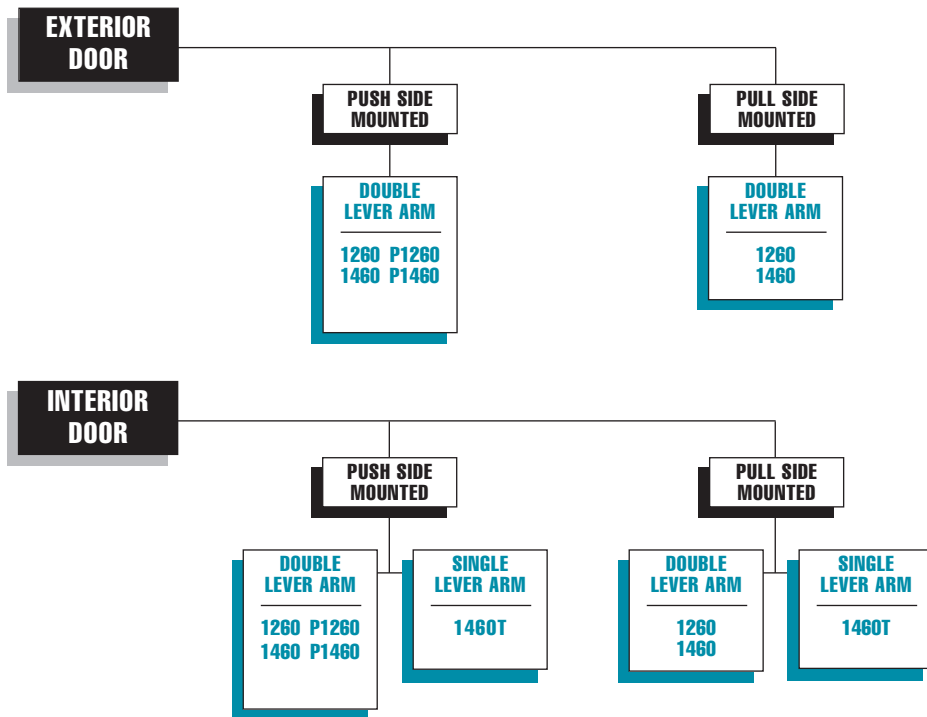

"P" = PARALLEL ARM MOUNTING

PRODUCT COMPARISON

This chart shows a basic comparison of LCN 1000 Series closers. Refer to the specific closer chapter for complete details.

| | MOUNTING | | | | | FINISH | | COVER | | | CYLINDER | | | *ARM FUNCTION | | | | | | | |
|-------|-------------------|-----------------|-----------------|--------------|-----------|-------------|--------|---------|-------|-----------------|------------|-----------|---------------|----------------|------------------|-------------------|------------|-----------|----------|------------|--------------|
| | HINGE (PULL) SIDE | TOP JAMB (PULL) | TOP JAMB (PUSH) | PARALLEL ARM | STOP FACE | POWDER COAT | PLAYED | PLASTIC | METAL | DESIGNER SERIES | NON-HANDED | NON-SIZED | ACCESSIBILITY | DELAYED ACTION | REGULAR (DOUBLE) | STANDARD (SINGLE) | HEAVY DUTY | HOLD-OPEN | EDA/MEDA | CUSH/HCUSH | SCUSH/SHCUSH |
| 1260 | ● | ○ | ● | ● | ○ | ● | ○ | ● | ○ | ○ | ● | ● | ♿ | ● | 180 | ○ | ○ | 180 | 120 | 110 | 110 |
| 1460 | ● | ○ | ● | ● | ○ | ● | ○ | ● | ○ | ○ | ● | ● | ♿ | ● | 180 | ○ | 180 | 180 | 110 | 100 | 100 |
| 1460T | ● | ● | ○ | ○ | ● | ● | ○ | ● | ○ | ○ | ● | ● | ♿ | ○ | ○ | 180 | ○ | 115 | ○ | ○ | ○ |

- AVAILABLE
- NOT AVAILABLE

♿ Closer available with less than 5.0 lbs. opening force on 36" door.

*Maximum opening/hold-open point with standard template. See individual closer series for degrees of opening per installation.

^D = For Designer Series only

1000 SERIES

APPLICATIONS

- ▶ For aluminum, hollow metal, or wood swinging doors and frames.
- ▶ Can be used with hinge or pivot mounted door.
- ▶ Mounts on 1 3/4" transom without adapter plates.
- ▶ Adapter plates and other installation accessories available for unusual conditions .

FEATURES COMMON TO 1000 SERIES

- ▶ 1000 series closers mount three ways. Closers with regular or hold-open arm mount hinge side or top jamb. Parallel arm, designated with a "P", closers include - 62PA SHOE required for parallel arm mount. 1460T mounts hinge side, top jamb (pull side) and stop face.
- ▶ Non-handed for right and left swinging doors.
- ▶ Closers to meet ADA reduced opening force requirements.
- ▶ Adjustable hydraulic backcheck cushions opening swing prior to 90°.
- ▶ Separate regulation of general closing speed and latching speed.
- ▶ Joints in arm and shoe adapt to uneven trim.
- ▶ Reversible shoe to boost latching power on double lever arms.

DESIGN ASSISTANCE

LCN has been providing reliable solutions to unique door control problems for over 75 years. Design and specification assistance are only a phone call away.

Contact LCN for assistance or technical information at **800-526-2400** or FAX **800-248-1460 (customer service)**, Fax **815-879-1495** for Application Engineering.

WARRANTY

10 year limited warranty. See General Section for complete warranty details.

SPECIFICATIONS

Refer to "SPECIFICATIONS" section for suggested architectural specifications.

MATERIALS

- ▶ High strength **cast iron** cylinder.
- ▶ **Forged steel** main arm for all EDA, Cush, 1460HD and 1460T Arms.
- ▶ One piece **forged steel** piston.
- ▶ Heat treated pinion.
- ▶ **All weather fluid** eliminates seasonal adjustments.
- ▶ **High efficiency, full complement**, low friction bearings.
- ▶ Tamper resistant regulating screws.
- ▶ Full rack and pinion hydraulic action.
- ▶ Quiet, low friction track and roller combination for all single lever arm closers.

FINISHES

- ▶ Available in seven standard or a wide selection of optional custom powder coat finishes to blend with door and frame.
- ▶ LCN's powder coat finish surpasses 100 hours of salt spray which is over four times the ANSI standard for corrosion resistance.
- ▶ For installations where a higher level of corrosion resistance is

required, LCN offers an optional special rust inhibiting (SRI) pre-treatment. Closers that combine the exclusive LCN powder coat finish and the SRI pre-treatment exceed the ANSI standard for corrosion resistance even further.

- ▶ Plated finishes are available as an option to accent door and frame for the 1460 Series closers.

LISTINGS & APPROVALS

UL listed for self-closing doors without hold-open under "SWINGING DOOR CLOSERS" (GVEV) file R 1943.

Tested and certified under ANSI Standard A156.4 grade one. Consult factory for details.

Consult factory for other listings such as; cUL, California State Fire Marshal, Bureau of Standards and Appeals.

POSITIVE PRESSURE

LCN closers have been certified for three hours by UL to be in compliance with UBC 7.2 (1997) and UL 10 C. Contact LCN for specific details on door closer fire ratings.

FASTENERS

1260, 1460, 1460T series closers are shipped with: A standard SELF-REAMING and TAPPING SCREW (SRT) pack that contains Philips head SRT screws to install the closer. Standard LCN thru bolts (TB) can be installed on 1 3/4" (44 mm) thick doors with 1/4-20 machine screws. Optional thru bolt (TB) sizes are available for 1 5/8" (41 mm) or 1 3/8" (35 mm) door thickness, but this must be specified when ordering.

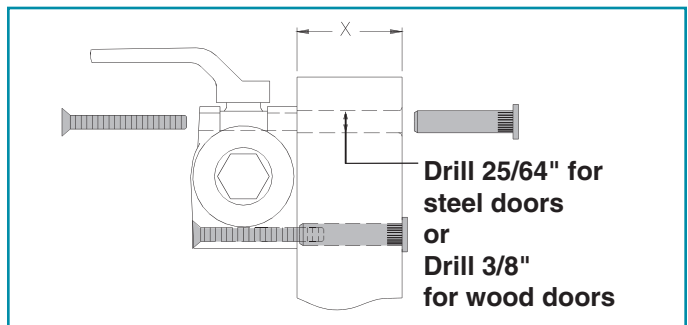

Note 1: For Through Bolts, specify door thickness if other than 1 3/4" (44 mm).

Note 2: Phillips head, metric machine screws are available, please specify.

Note 3: LCN recommends the use of wood screws in wood door applications.

MAINTENANCE

Closers mounted according to LCN installation instructions require no periodic maintenance or adjustments.